

AWARE

ENABLING EWS GALILEO MARKET UPTAKE IN WIDESPREAD PWS

D1.05a MS1 - KICK-OFF MEETING MINUTES



Funded by the
European Union



This project has received funding from the European Union Agency for the Space Programme under HORIZON-EUSPA-2021-SPACE grant agreement No 101082555.

Funded by the European Union. Views and opinions expressed are however those of the author(s) only and do not necessarily reflect those of the European Union or the European Union Agency for the Space Programme. Neither the European Union nor the granting authority can be held responsible for them.

WP1 – Project Management and Coordination

MS1 - Kick-Off Meeting Minutes

Grant Agreement No:	101082555
Project acronym:	AWARE
Project title:	Enabling EWS Galileo market uptake in widespread PWS
GA delivery date:	
Deliverable No:	D1.05a
Submission date:	27-09-2024
Version:	1.1
Author:	Charly Faradji
Lead institution:	Telespazio France
Partners contributing:	All
Dissemination Level*: (PU, SEN, EUCL)	PU



***PU** = Public — fully open (automatically posted online), **SEN** = Sensitive — limited under the conditions of the Grant Agreement, **EU CL** = EU classified — EU-RESTRICTED, EU-CONFIDENTIAL, EU-SECRET under Decision 2015/444

MS1 - Kick-off Meeting Minutes

CHANGE RECORD

Issue	Date	Change	Author
0.1	27 Nov 2023	Creation of the document	TPZF
1.0	21 Dec 2023	First version of the document	TPZF
1.1	27 Sept 2024	Annexing slides from Delta KoM	TPZF

MS1 - Kick-off Meeting Minutes

TABLE OF CONTENT

CHANGE RECORD 2

TABLE OF CONTENT..... 3

1 AGENDA..... 4

2 ATTENDEES LIST 5

3 ACTION SUMMARY 6

4 ANNEXES 7

MS1 - Kick-off Meeting Minutes

1 AGENDA

Time	Subject	Presenter
09:00	Welcome and quick round table	All
09:20	Presentation of EWSS	EUSPA – M. Lopez-Martinez
09:50	Presentation on project monitoring process	EUSPA – M. Lopez-Martinez
10:20	General presentation with main objectives	SYR – C. Boissy
10:50	COFFEE BREAK	
11:10	Presentation of each consortium member	All
12:30	LUNCH BREAK	
13:30	WP1 Objectives, tasks and deliverables	SYR – C. Boissy
13:50	WP2 Objectives, tasks and deliverables	TPZF – A. Pomies
14:10	WP3 Objectives, tasks and deliverables	SYR – C. Boissy
14:30	WP4 Objectives, tasks and deliverables	SYR – C. Boissy
14:50	WP5 Objectives, tasks and deliverables	TPZF – A. Pomies
15:10	WP6 Objectives, tasks and deliverables	EENA – A. Olson
15:30	Final Considerations	All
16:00	END OF MEETING	

MS1 - Kick-off Meeting Minutes

2 ATTENDEES LIST

Siglum	Name	Attendance
EUSPA	Manuel LOPEZ MARTINEZ	On site
EUSPA	Vasileios KALOGIROU	On site
RHEA	Pauline MARTIN	Remote
SYR	Cyril BOISSY	On site
TPZF	Axelle POMIES	On site
TPZF	Laurent ARZEL	Remote
TPZF	Caroline MORISOT-PAGNON	Remote
TPZF	Soufian AYACHI	Remote
GENA	Carlos ESCARPA	On site
JCD	Timmy FLOUME	On site
JCD	Benoit SAMSON	Remote
JCD	Frederic CHANSON	Remote
CNES	Mathilde FOULON	On site
CNES	Maaïke DOORN	Remote
CNES	Sylvain DELATTRE	Remote
EENA	Alexandra OLSON	On site
EENA	Benoit VIVIER	On site
UNISTRA	Stephen CLANDILLON	On site
UNISTRA	Stéphanie BATTISTION	Remote
URSZR	Romana NAGLIČ	On site

MS1 - Kick-off Meeting Minutes

3 ACTION SUMMARY

N	Description	Owner	Due date	Statut @KOM	Statut Dec 2023
1	Provide inputs required for the project (cf. mail sent on 30/11/2023)	EUSPA / M. Lopez-Martinez	15/01/2023	On going	On going
2	Verify with legal at JCD possibility to use EWOKS name (trademarked by Lucas Film)	JCD / T. Floume	31/12/2022	New	Closed
3	To confirm the planning of RTB readiness for EWS because it will be needed for EWOKS demonstration => End Q2 2023, RLSTB will be ready	CNES / M. Foulon	31/12/2022	Closed	Closed
4	Draft press release by EENA to circulate in consortium	EENA / A. Olson	15/12/2022	New	Closed
5	Upload on the platform the GA & CA	SYR / C. Boissy TPZF / A. Pomies	16/12/2022	On going	On going
6	To provide access to the EU-EWOKS platform to Mathilde	SYR / C. Boissy	21/12/2022	New	Closed
7	Planify meetings to discuss Social Media / Website (domain name / URL)	SYR / C. Boissy	15/12/2022	New	Cancelled
8	Create a Syrlinks OwnCloud platform for Data Management	SYR / C. Boissy	15/12/2022	New	Cancelled
9	EUSPA sharing information about reviewers and potential conflict of interest	EUSPA / M. Lopez-Martinez	08/12/2022	On going	Closed

MS1 - Kick-off Meeting Minutes

4 ANNEXES

Annex 1: Slides from AWARE official KoM held on the 07/12/2023

Annex 2: Slides from AWARE delta KoM held on the 08/11/2023

MS1 - Kick-off Meeting Minutes

END OF DOCUMENT

Syrlinks

ACTIVITÉS SPATIALES ET DE DÉFENSE



EWOKS PROJECT – KICK OFF MEETING – PRAGUE | 07
November 2022

> GENERAL

- PROJECT NAME EWOKS
 - Enabling EWS/Galileo Market Uptake in widespread PWS Solutions
- DURATION : 26 Months
 - TO : 1st Nov. 2022 => end Dec. 31 st 2024
- 8 PARTICIPANTS
 - 3 COUNTRIES : FRANCE – SPAIN – BELGIUM – SLOVENIA
- TOTAL ELIGIBLE EXPENSE :
 - 3,5 M€
- TOTAL MAX GRANT :
 - 2,6 M€

> GENERAL, CONTEXT, GOALS

- More & More threats
 - human driven or natural disasters
- EWS launch in 2023
 - broadcasted by Galileo satellite
 - targeting Public Warning Services (PWS)
- EWS received on smartphones for individuals
- Build a beacon & end-to-end system solution
 - to receive EWS Galileo signals authenticate them,
 - send video/visual/audio or text alerts to population through various equipments (LRAD, Digital Displays, panels, etc)
- Reinforce positive impact on Rapid Mapping of Disaster area from Copernicus

> CONSORTIUM & ROLES

- **SYRLINKS** (FRANCE) : Coordinator, [Beacon design](#)
 - Cyril BOISSY
- **TELESPAZIO** (FRANCE) : Participant, [SW IP to decode EWM & give instructions](#)
 - Axelle POMIES
- **JC DECAUX** (FRANCE) : Participant, User / Beacon integrator ([Digital displays](#) of EWM)
 - Timmy FLOUME
- **GENASYS** (SPAIN) : Participant, User / Beacon integrator ([LRAD](#) of EWM)
 - Carlos ECARPA
- **EUROPEAN EMERGENCY NUMBER ASS.** (BELGIUM): Participant / [Dissemination](#)
 - Alexandra OLSON, Benoit VIVIER
- **CNES** (FRANCE) : Participant / [Operator of the Galileo RLS](#) in Toulouse
 - Mathilde DUFOUR
- **UNISTRA** (FRANCE) : Participant / [Rapid mapping of disasters](#) / Copernicus
 - Stephen CANDILLON
- **SLOVANIA CIVIL PROTECTION** : Participant / [End User Civil Protection](#)
 - Romana NAGLIC

> CONTACT DETAILS

Name of Participant to KOM	COMPANY / ENTITY	Email
Mr. Cyril BOISSY	SYRLINKS	cyril.boissy@syrlinks.com
Mathilde Dufour	CNES	mathilde.dufour@cnes.fr
Ms Alexandra OLSON	EENA	ao@eena.org
Mr Benoit VIVIER	EENA	bv@eena.org
Carlos Escarpa	GENASYS	cescarpa@genasys.com
Timmy Floume	JCDECAUX	timmy.floume@jcdecaux.com
Axelle Pomies	TELESPAZIO	axelle.pomies@telespazio.com
Stephen Clandillon	UNISTRA	s.clandillon@unistra.fr
Romana Naglič	URSZR	romana.naglic@urszr.si

> BUDGETS

Short name	Legal name	Ctry	PIC	Total eligible costs (BEN and AE)	Max grant amount
SYRLINKS	SYRLINKS SAS	FR	954906025	1 434 272,50 €	1 003 990,75 €
TPZF	TELESPAZIO FRANCE SAS	FR	997899044	796 376,25 €	557 463,00 €
JCDecauxSA	JCDECAUX SA	FR	919418187	375 000,00 €	262 500,00 €
Genasys	GENASYS II SPAIN SA	ES	950733570	505 375,00 €	353 762,50 €
EENA	EUROPEAN EMERGENCY NUMBER ASSOCIATIONASBL	BE	997490577	284 062,50 €	284 062,50 €
CNES	CENTRE NATIONAL D'ETUDES SPATIALES - CNES	FR	999599163	89 750,00 €	89 750,00 €
UNISTRA	UNIVERSITE DE STRASBOURG	FR	996569950	57 812,50 €	57 812,50 €
URSZR	Uprava RS za zaščito in reševanje, Ministrstvo za obrambo	SI	992626027	- €	- €
				3 542 648,75 €	2 609 341,25 €

> LIST OF WPs

WP	LEADER	TITLE
WP1	SYRLINKS	Project management and coordination
WP2	TELESPAZIO	Product & Service Specification and Design
WP3	SYRLINKS	Products development
WP4	SYRLINKS	EWOKS Integration and validation
WP5	TELESPAZIO	EWOKS Demonstration
WP6	EENA	Exploitation and Dissemination

> PROJECT MILESTONES & FINANCIAL REPORTING PERIOD

Milestone Name	Work Package No	Lead Beneficiary	Means of Verification	Due Date(month)
MS1- Kick-Off meeting	WP1	1-SYRLINKS	MoM	1
MS2 - System definition readiness	WP2	2-TPZF	Deliverables of WP2	6
MS3 - EWOKS ready for integration	WP3	1-SYRLINKS	Deliverables of WP3	15
MS4 - EWOKS ready for deployment	WP4	1-SYRLINKS	Deliverables of WP4	20
MS5 - Final review	WP6	1-SYRLINKS	Devliverables of WP6	24

REPORT PERIOD	WHEN	TITLE
1	Initial pre-financing	30 days after signature of GA
2	M1 to M13	Interim payment
3	M14 to M24	Final Payment

We are here

> WORK PLAN

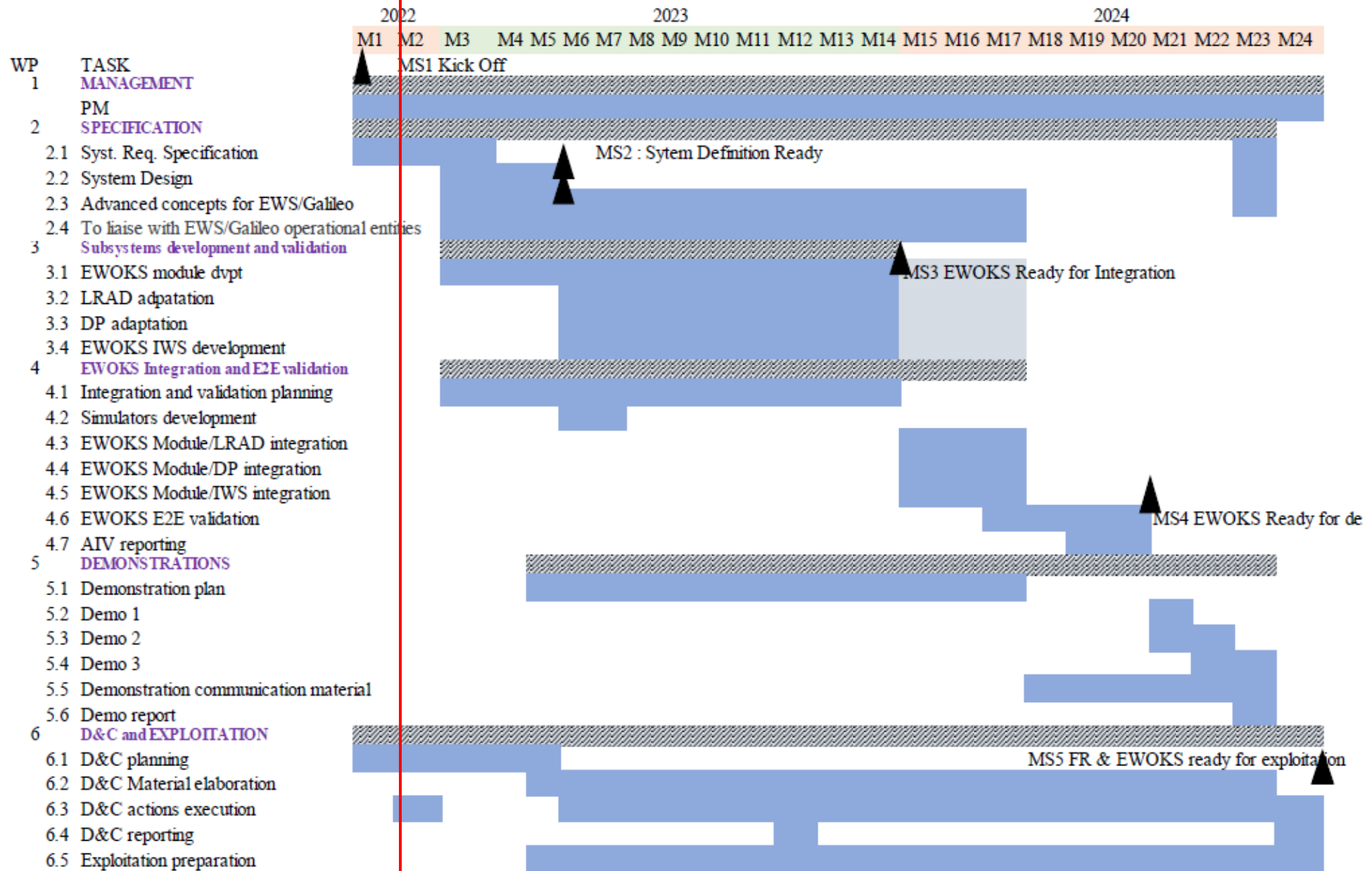

> RISK & MITIGATION



Description of Risk

Delay on Galileo EWS availability for demonstrations (M/H)

Hindrance & delay due to Galileo security rules (L/M)

Participant leaving the project (L/H)

Lack of interest from Copernicus EMS stakeholders in the proposed concept and associated service, or in participating in linking the 2 services (L/M)

Unavailability of EWS ICD at the start of the project (L/M)

Non-provision by EUSPA of authorisation to perform EWOKS demonstrations (L/H)



Proposed Mitigation Measures

In case of a delay, we would use the CNES RLS Testbed or we would request access to the outcomes of the EWS demonstrator, project lead by E.C.

presence of TPZ-F, CNES and EENA to avoid or to supersede

Since the beginning of the consortium creation, we have emphasised the reasons of participation and interest of each partner. During the project, SYR will ensure that both the quality of experience, relationship and outcomes are carefully managed in order to minimise the possibility of a participant leaving the project.

To involve CEMS stakeholders (DG JRC, DG ECHO-ERCC) at an early stage of the project, and DG DEFIS to ensure the effective implication of CEMS

The project will work based on the most up-to-date version of the EWS ICD available (to be provided by EC/EUSPA)

CNES will provide EUSPA with evidences that the EWOKS demonstrations do not induce new risk and has no impact on the RLSP's accreditation perimeter.

> SYLINKS PM organization (to be validated, in discussion)

- Syrlinks Project Manager deditacted (onboarding Feb.23)
 - Technical for internal Syrlinks & external Consortium discussions
 - Report to EUSPA
 - Maintain Planning
- Support from Consulting Group
 - Help in Admin & Financial reporting
 - Help in managing meetings, Models of documents
 - Follow progress of all deliverables
 - Help for periodic & final reports
 - Data management plan
 - Help in dissimulation & communication
- Transfer from man-days to subcontracts budget
- Same Max Grant amount (no increase)

> KOM Minutes & Actions

N°	Description	Owner	Date	Statut
1	Provide EWS ICD and message format	Manolo / EUSPA	Jan 15th (ASAP)	On going
2	Verify with legal at JCD possibility to use EWOKS name (trademarked by Lucas Film)	Timmy /JCD	Dec 31st	To be started
3	To confirm the planning of RTB readiness for EWS because it will be needed for EWOKS demonstration => End Q2-2023, RLSTB will be ready	Mathilde / CNES	Dec 31st	Closed
4	Draft press release by EENA to circulate in consortium	Alexandra / EENA	Dec 15th	To be started
5	Upload on the platform the GA & CA	Cyril / Syrlinks	Dec 16th	On going
6	To provide access to the EU EWOKS platform to Mathilde	Cyril / Syrlinks	Dec 21st	Not started
7	Planify meetings to discuss Social Media / Website (domain name / URL)	Cyril / Syrlinks	Dec 15th	Not Started
8	Create a Syrlinks OwnCloud platform for Data Management	Cyril / Syrlinks	Dec 15th	Not Started
9	EUSPA sharing information about reviewers and potential conflict of interest	Manuel / EUSPA	Dec 8th	On going

> **WP1** - Project management and coordination

D1.1 – D1.2 Consortium Agreement

D1.2 – D1.1 Grant agreement

D1.3 – D1.3 Project management plan

D1.4 – D1.4 Progress Reports

D1.5 – D1.5 Minutes of meeting

D1.6 – D1.6 Data Management Plan

D1.7 – Quarterly Report 1

D1.8 – Quarterly Report 2

D1.9 – Quarterly Report 3

D1.10 – Quarterly Report 4

D1.11 – Quarterly Report 5

D1.12 – Quarterly Report 6

D1.13 – Quarterly Report 7

D1.14 – Quarterly Report 8

- Syrlinks is leader
- But all contribute in content if applicable and review document

> PM & Stakeholders

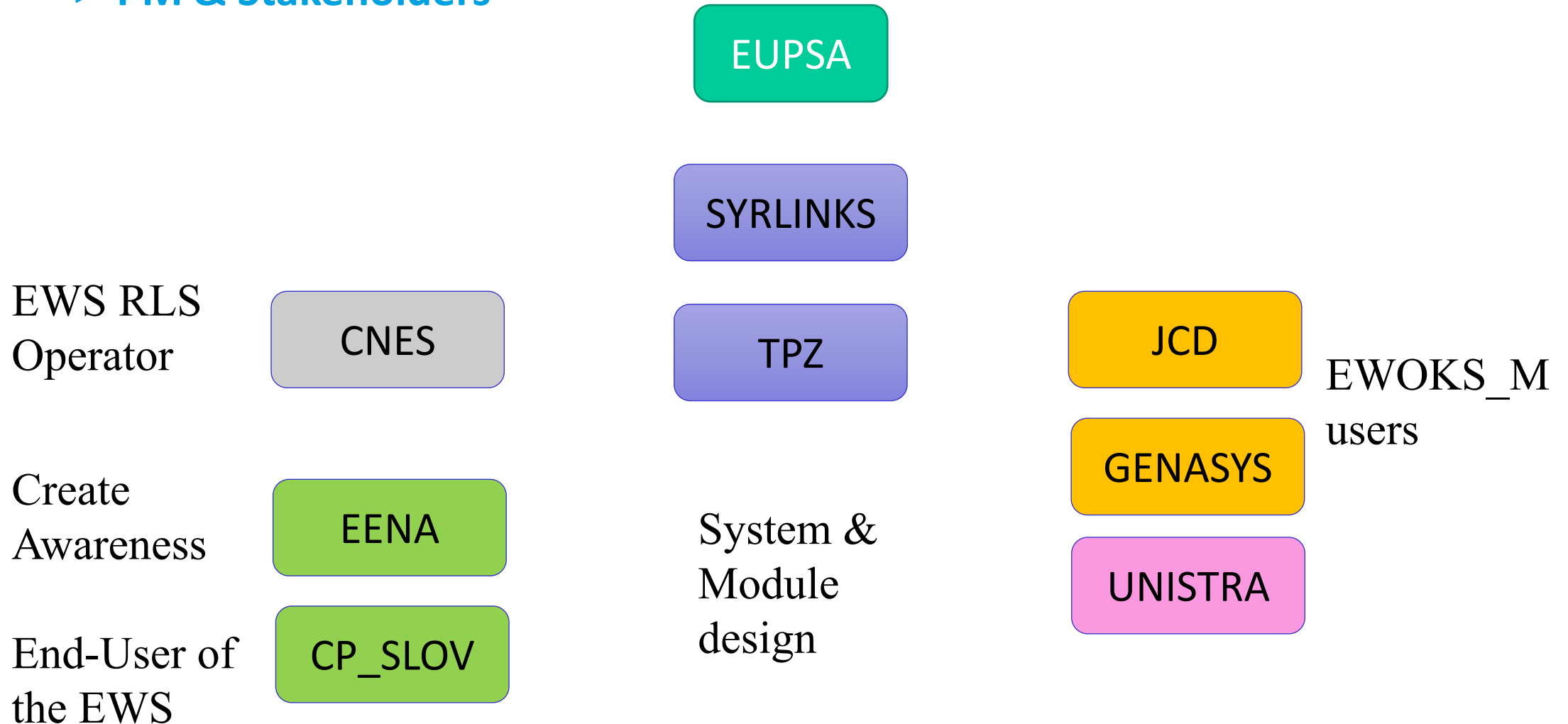

> Expenses reporting ; good (correct) practices

- Log precisely Man-days / Hours WHO / WHEN / HOW MANY
 - Labor cost must be justified (payslips evidence), computed by individuals
 - Man rate is not environmentated (overheads), it is cost of labor for the entity
- Subcontacts => Keep invoices that you declare as eligible costs
 - Together with the payments made by wiretransfer (as proof of payment)
- Travel expenses
 - Keep invoices & proof of payment also

> WP1 : Communication within the Consortium

- To decide frequency of progress meetings (baseline is Monthly)
- Bi-monthly in the beginning to put things on tracks (first 3 months)
- Every 6 months, physical meetings (rolling locations)
 - KOM Prague Dec 7th 22 [Icebreaker yesterday night]
 - Fundamental concept to have meeting at each location one time
 - Toulouse ? Paris? Strasbourg ? Lubiana ? Brussels ? Rennes ?

Work Package 2

Work Package 2 - Product & Service specification and design

Technical Approach

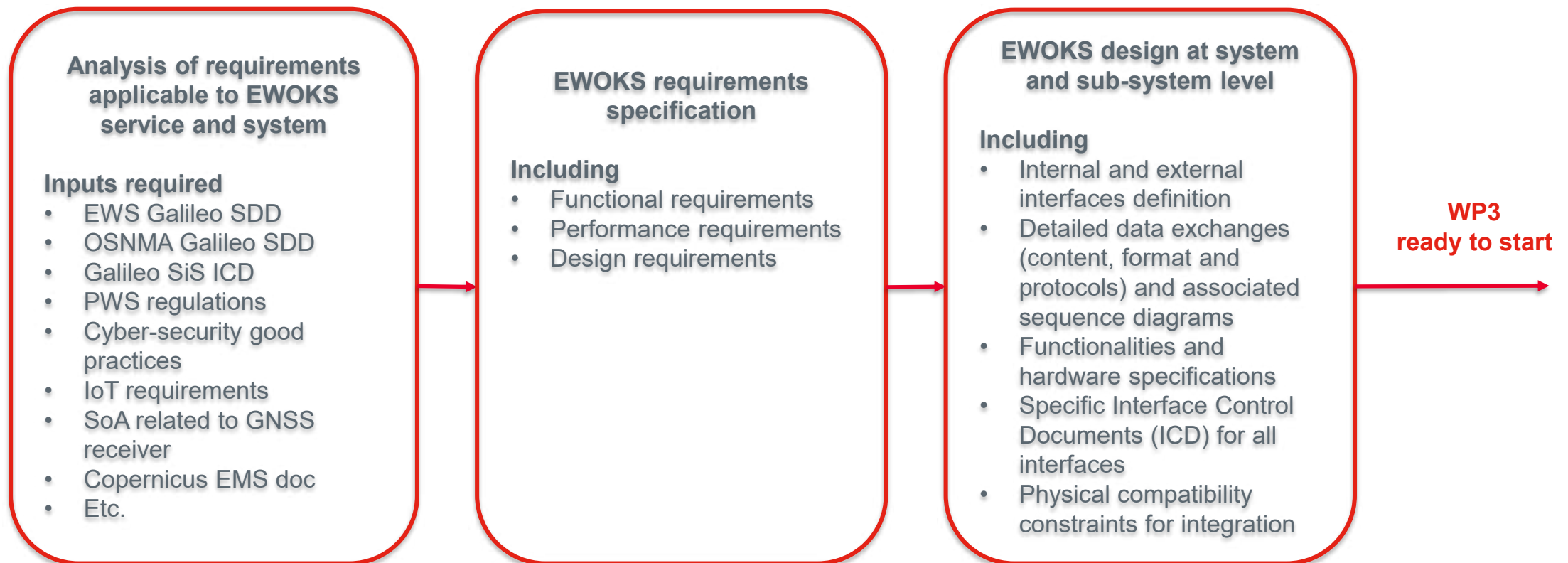



Work Package 2 - Product & Service specification and design

Technical Approach

Support to EC/EUSPA on advanced concepts definition for Galileo EWS evolutions

- Identification all relevant actions (regulation, standardisation, awareness raising...) to led to foster Galileo EWS adoption and support to EC/EUSPA to perform some of them
- Recommendations on potential Galileo EWS evolutions
- Analysis potential synergies betw Galileo EWS and Copernicus EMS and selection of the most relevant ones to be demonstrated in the project
- Takling barriers that may hinder the EWS uptake, such as: How the EC and EUPSA can be protected against geofencing rules infringement by a EWS receiver manufacturer? How a EWS receiver is qualified? Is there a need for a receiver type approval?

Liaison with EWS/Galileo operational entities

To ensure smooth EWOKS integration into Galileo EWS



Work Package 2

Description

Lead : TPZF

Participants : SYR, JCD, GENA, EENA, CNES, UNISTRA

Objectives : To specify the requirements on the EWOKS system, service at system level and subsystem level

Description of work

- Task 2.1 : To specify the requirements on the EWOKS system and service at system level and subsystems level (TPZF, all)
- Task 2.2 : To design the EWOKS system and service at system level and subsystems level (TPZF, all)
- Task 2.3 : To support EC and EUSPA on the definition of advanced concepts for Galileo EWS evolutions
- Task 2.4 : To liaise with EWS/Galileo operational entities

Deliverables

- D2.1 Initial EWOKS requirements specification M3
- D2.2 Initial EWOKS design document including the external and internal interfaces definition M5
- D2.3 Contributions to EWS/Galileo evolutions definition concerning EWOKS like services M17
- D2.4 Initial Contribution to the definition of EWS/Galileo-EWOKS interfaces M6
- D2.5 Final EWOKS requirements specification M23
- D2.6 Final EWOKS design document M23
- D2.7 Final Contribution to the definition of EWS/Galileo-EWOKS interfaces M23

Duration : M1-M23

> **WP3 : Beacon development** **M3 => M15**

D3.1 – D3.1 EWOKS Module

D3.2 – D3.2 Adapted LRAD

D3.3 – D3.3 Adapted DP

D3.4 – D3.4 EWOKS enabled In-door warning system

- Identify SW needs to get EWOKS module architecture as quick as possible for SW development
- Identify mechanical aspects for latter intégration into DP, LRAD, IWS
 - CPU size, Memory, network interface, OS (what type)
 - Mechanical ICD
 - Electrical ICD
 - OS-NMA authentication
 - Give EWM to TPZ IP the EWM for latter processing (CAP message etc.)

> WP3 : Beacon development & EWOKS Module fonction

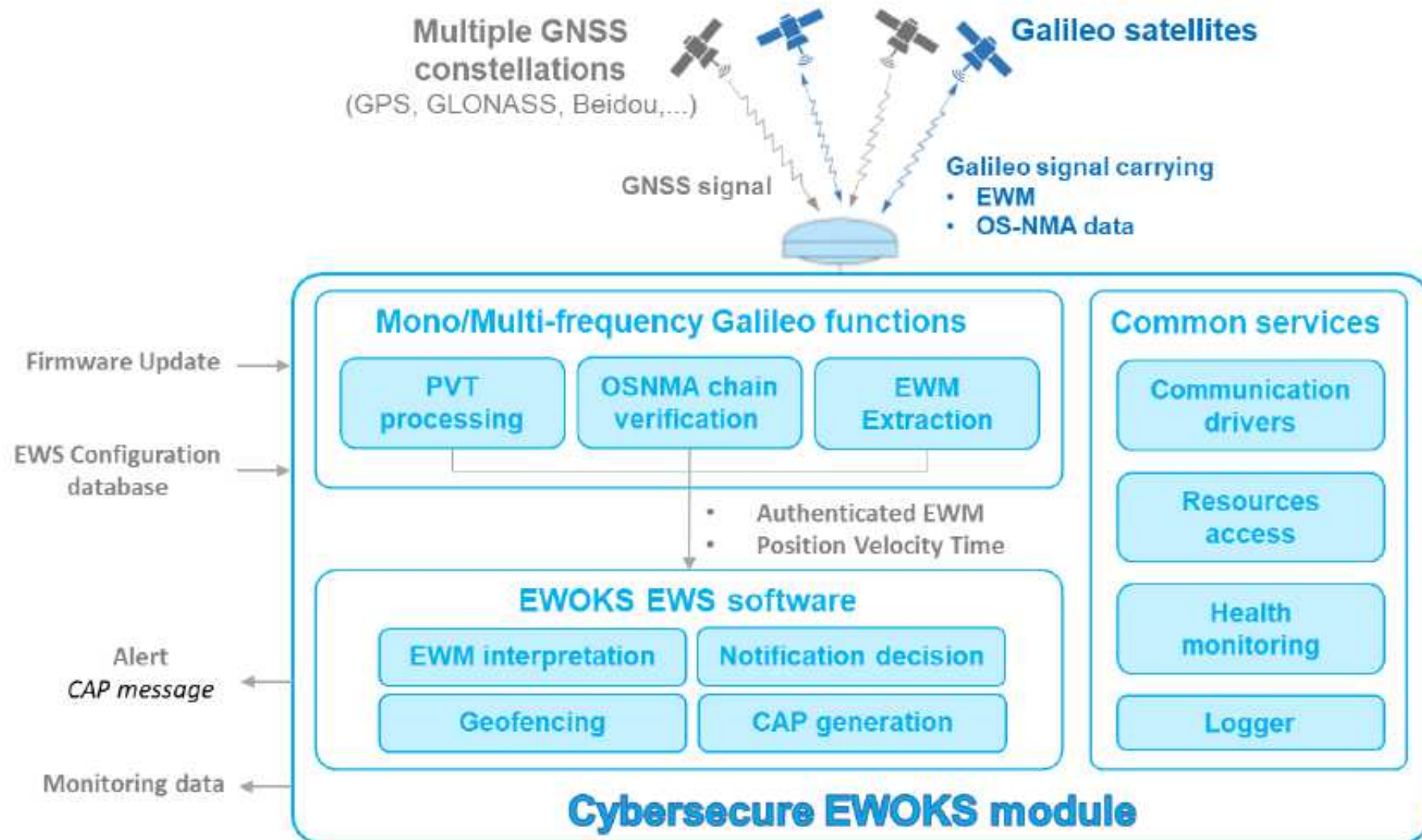

> EWOKS_M

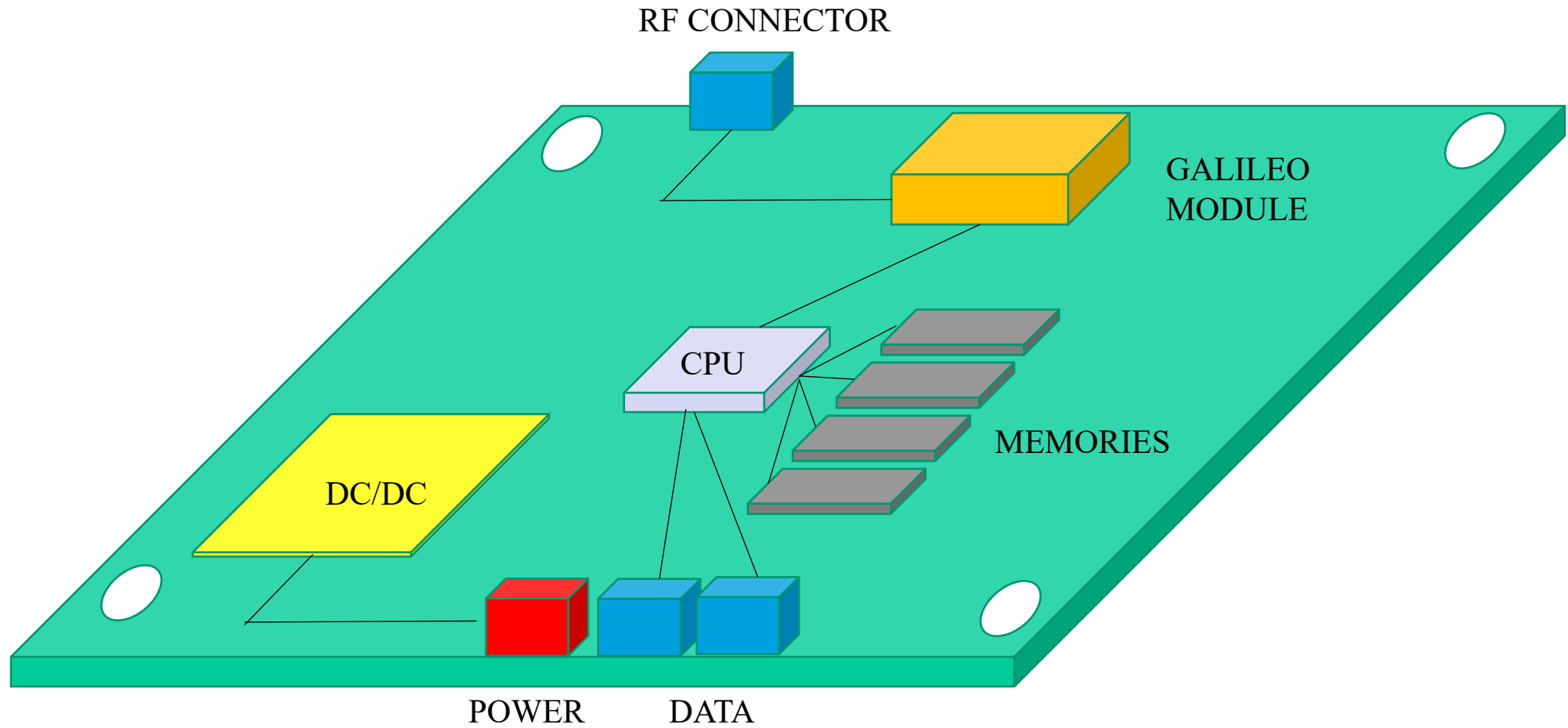

> WP4 : EWOKS Integration and validation

- This step comes after the development and the initial tests done in laboratory
- 3 devices to integrate the EWOKS_M
 - DP (JCD)
 - LRAD (GENASYS)
 - IWS (TPZ)
- JCD & Genasys & TPZ integrate the module into their devices and test/validate it in an end-to-end approach
 - ATP : Test Plan to define, method of test
 - ATR : Acceptance Test report
- Get final acceptance, bug free, before moving to Demonstration step WP5

Work Package 5



Work Package 5

Technical Approach – Demonstration Use Cases

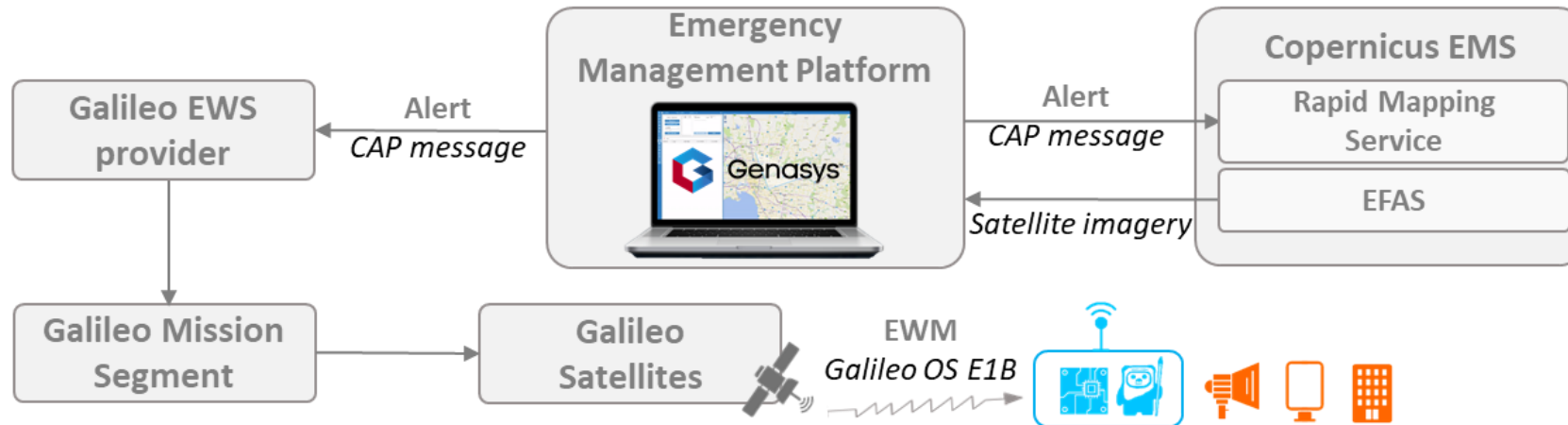

Use Case	1 Natural disaster	2 Urban emergency	3 Industrial catastrophe
Fixed Terminal	Long Range Acoustic Device (LRAD)	Digital Panel & LRAD	Indoor Warning Systems & LRAD
Disaster type	Floods	Terrorism attack	AZF explosion
Alert player	Loudly spoken alert	Text displayed on panel & Loudly spoken alert	Notification on PC / screens & Loudly spoken alert



Work Package 5

Description

Lead : TPZF

Participants : SYR, JCD, GENA, EENA, CNES, URSZR, UNISTRA

Objectives : To Demonstrate the EWOKS service in operational context for the 3 uses cases

Description of work

- Task 5.1 To plan the EWOKS demonstration (TPZF, all)
- Task 5.2 To execute the EWOKS demonstration for the Natural Disaster Use Case (GEN, all)
- Task 5.3 To execute the EWOKS demonstration for the Industrial Catastrophe Use Case (TPZF, all)
- Task 5.4 To execute the EWOKS demonstration for the Urban Emergency Use Case (JCD, all)
- Task 5.5 To collect live data and elaborate Communication material to support Dissemination, Communication activities
- Task 5.6 To report on the EWOKS demonstrations and feed the EWOKS final definition with feedback from demonstrations (TPZF, all)

Deliverables

- D5.1 Initial EWOKS demonstrations plan M9
- D5.2 Final EWOKS demonstrations plan M17
- D5.5 EWOKS Demonstrations Communication Material M23
- D5.6 EWOKS demonstrations report M23
- D5.7 Security Analysis report M18

Duration : M5-M23



EWOKS

WP6- Exploitation and Dissemination

December 7th, 2022

Overview



- I. What has been done?
- II. What will be done?
- III. Deliverables
- IV. Future consortium contributions

December 7th, 2022



What has been done?

- Press release

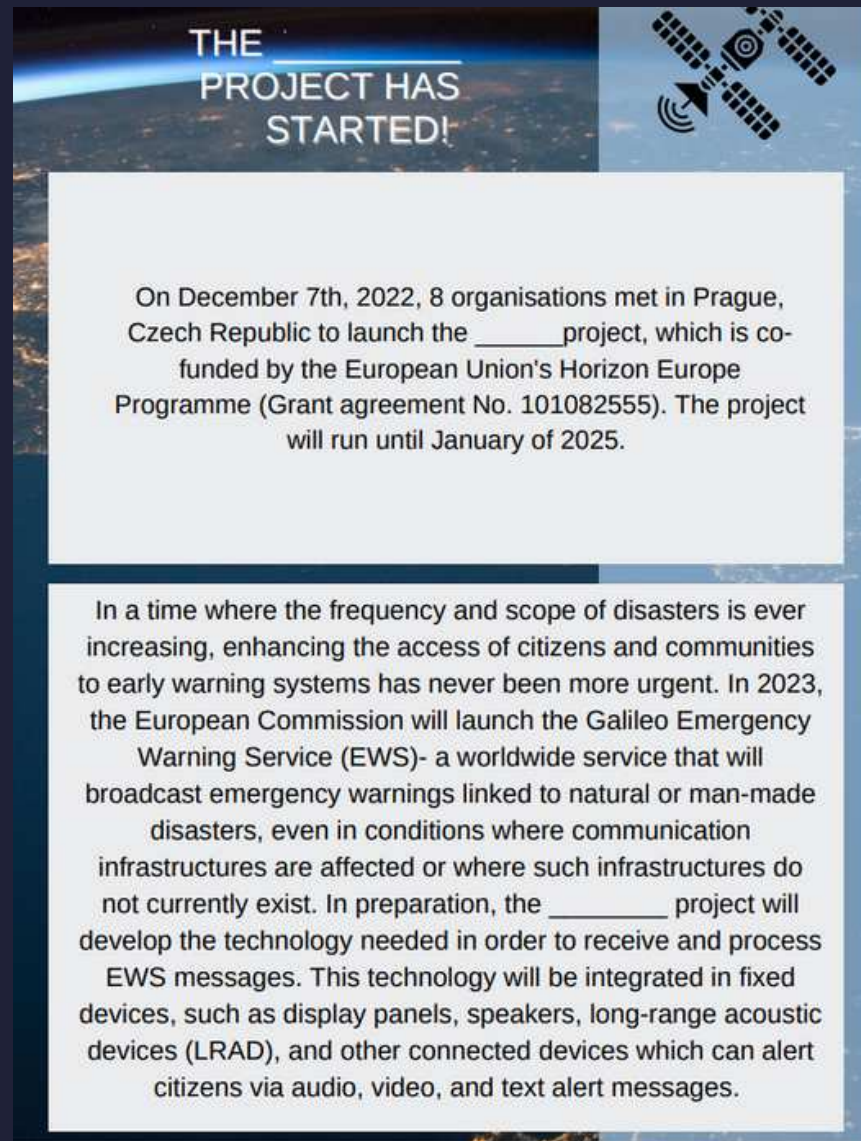

- Developing "brand kit"

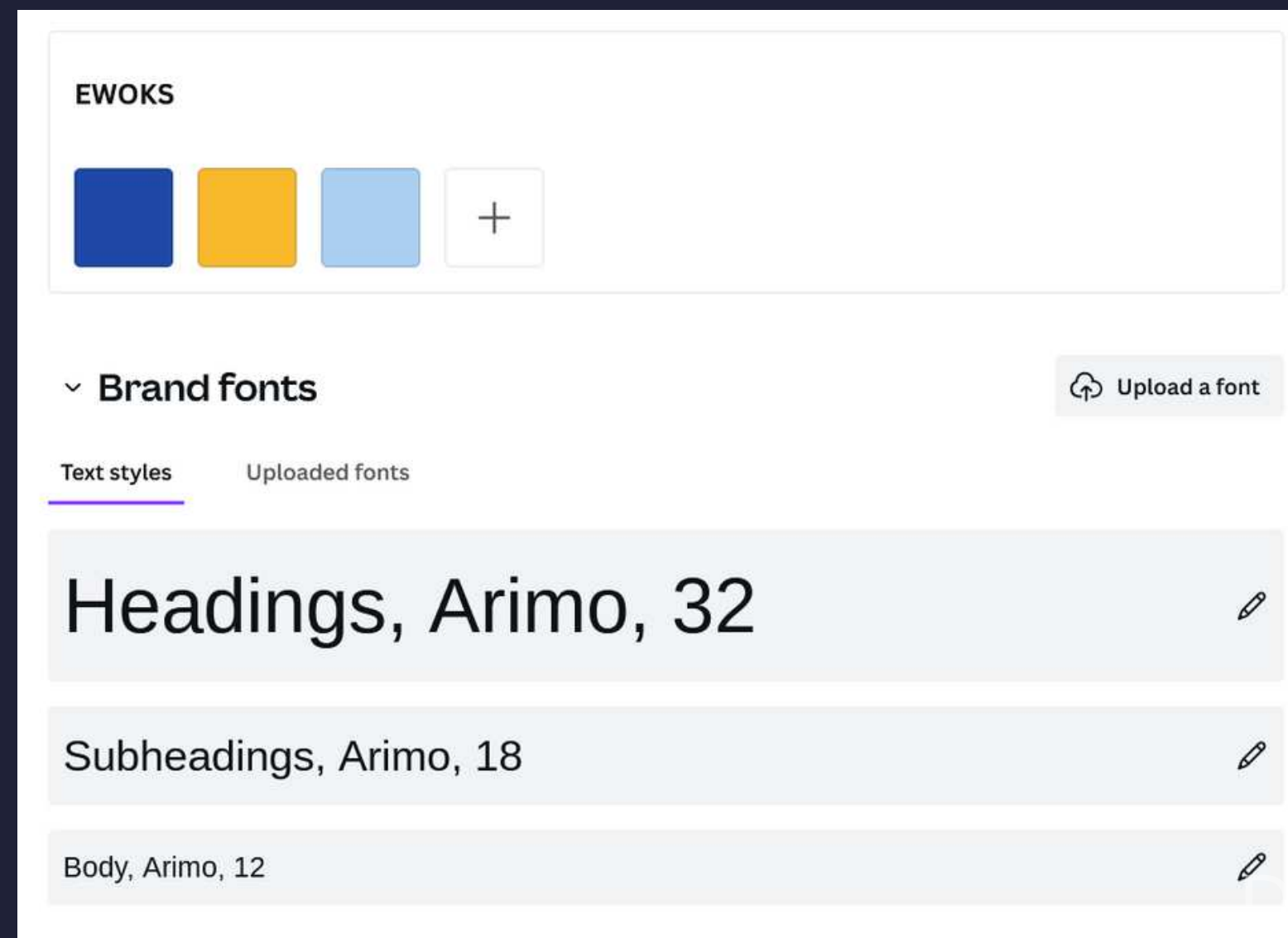

December 7th, 2022

What will be done?



Raise general awareness and enhance the reputation of Galileo EWS



Promote engagement and communication



Exploitation

December 7th, 2022

What will be done?



Finish brand kit (logo, templates)

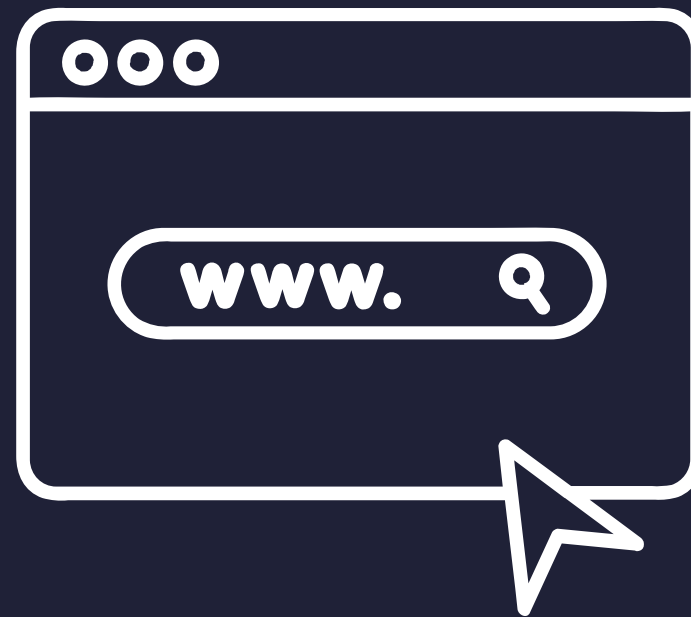

Create website



Create social media accounts

December 7th, 2022

What will be done?



Keeping members up to date about Galileo EWS and it's potential

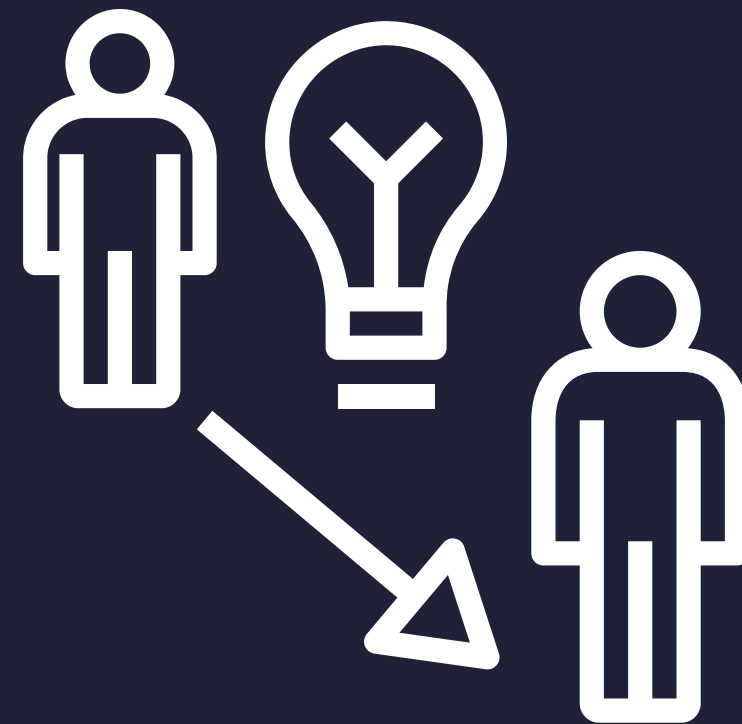

Extend networks and share knowledge

December 7th, 2022

Deliverables

- D6.1 Initial communication and dissemination plan (EENA)- M3
- D6.2 Final communication and dissemination plan (EENA)- M12
- D6.3 Initial business plan (Syrlinks)- M5
- D6.4 Final business plan (Syrlinks)- M24
- D6.5 Various communication and dissemination support materials (EENA)- M24

December 7th, 2022

Future Consortium Contributions

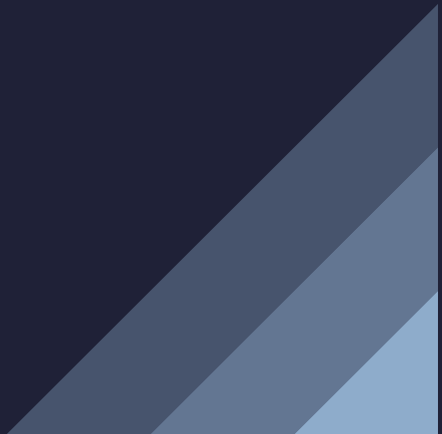

- Reposting content from social media from project's accounts
 - Contributing to bios- "Meet our consortium"
 - Contributing blog posts
 - Regarding the work that is being conducted, past disasters and what role EWS could have played, demonstrations, conferences, events, etc.
- 

December 7th, 2022



*Thank
you!*



December 7th, 2022

Telespazio France

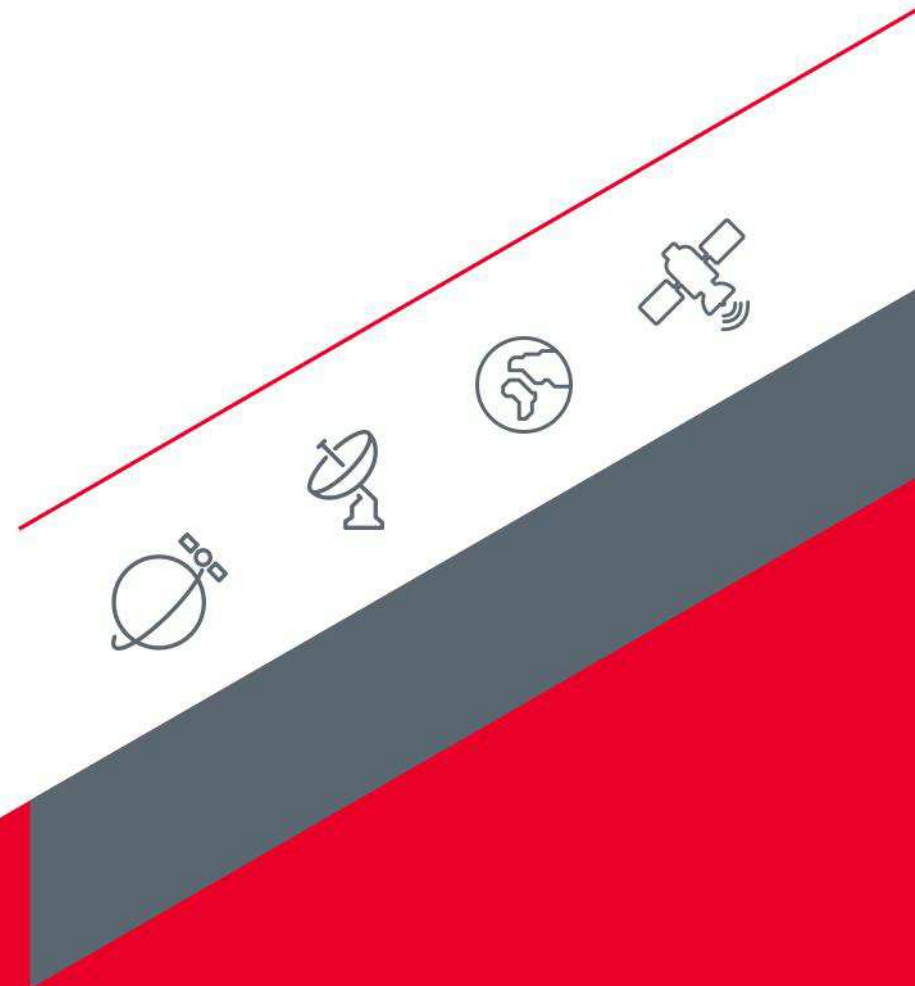

—
Prague – KO EWOKS – 7 December 2022



Telespazio Group - International footprint

Summary



Headquarter
in Rome (Italy)

605 M€
Turn over

3 100 employees

25 implantations,
in Europe & South
America

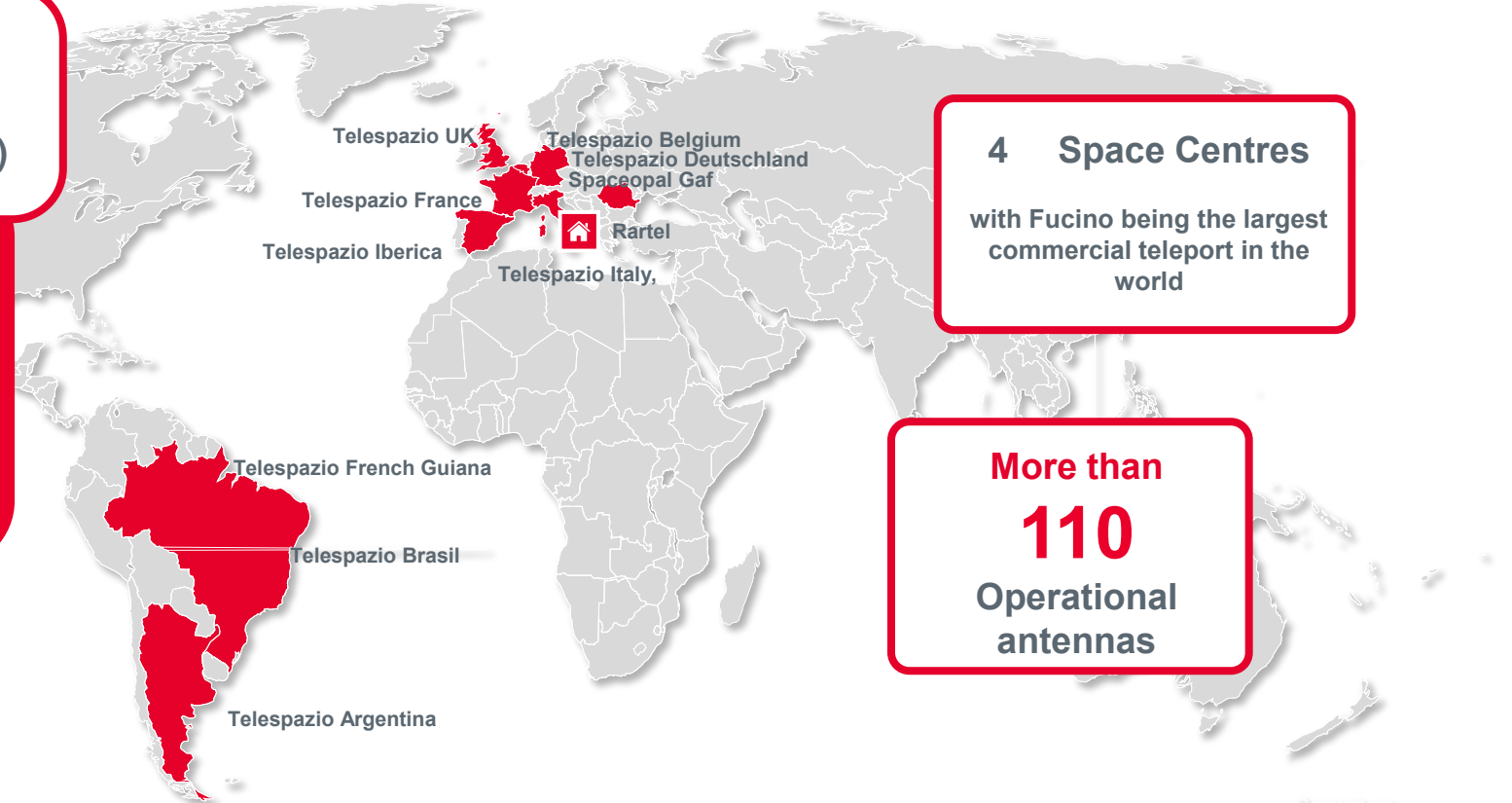

4 Space Centres

with Fucino being the largest
commercial teleport in the
world

More than

110

Operational
antennas

Telespazio France - Strength of a human sized company



Headquarter
in Toulouse
(France)

96 M€
Turn over

450 employees

4 establishments
in mainland
and Over Seas



Kourou



OUR ESTABLISHMENTS

- Toulouse
- Kourou
- Paris
- Bordeaux



Our Business

Telespazio is involved in the main domains of the space business and deploys its expertise in three family of services

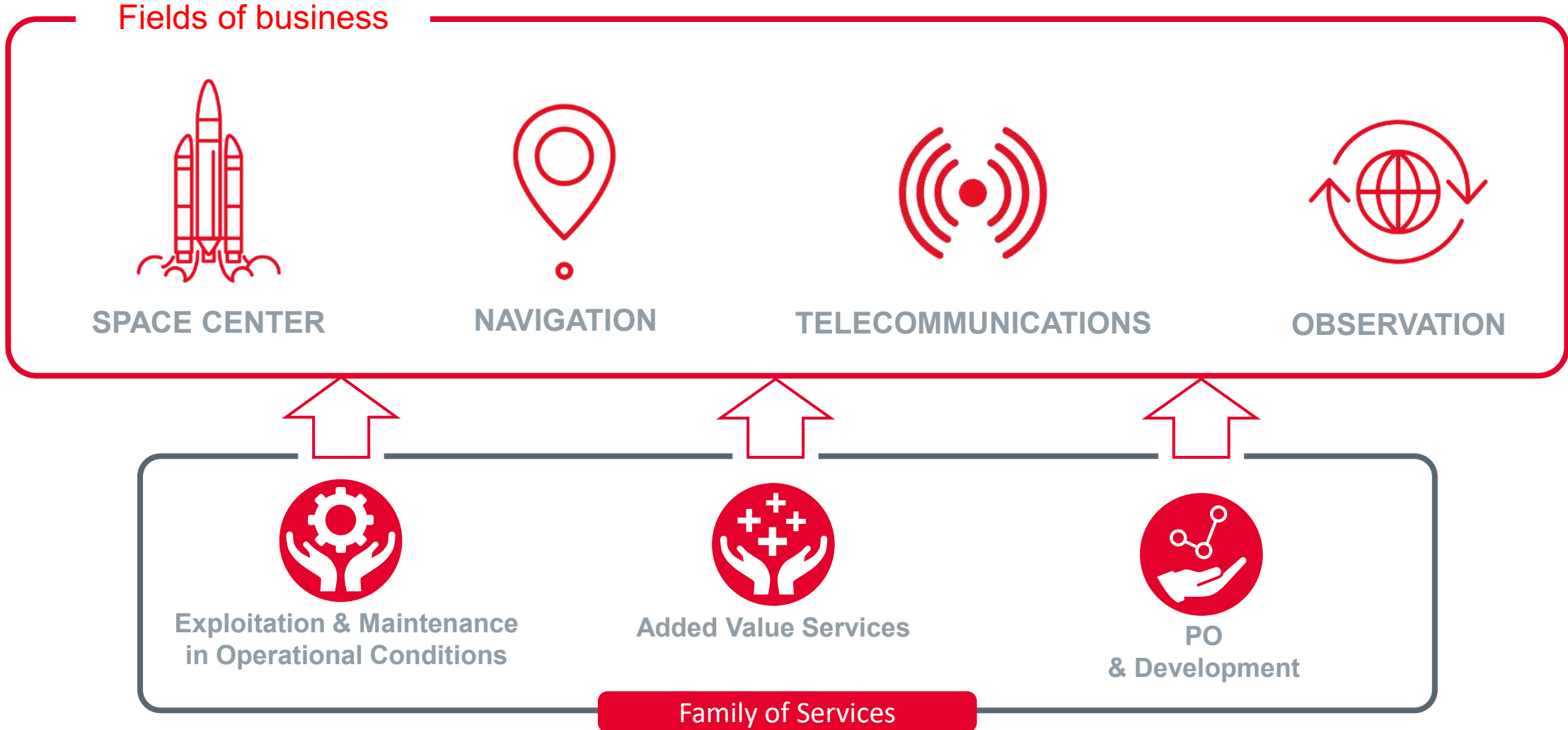



Telespazio Strategy

Innovate, Build & Operate

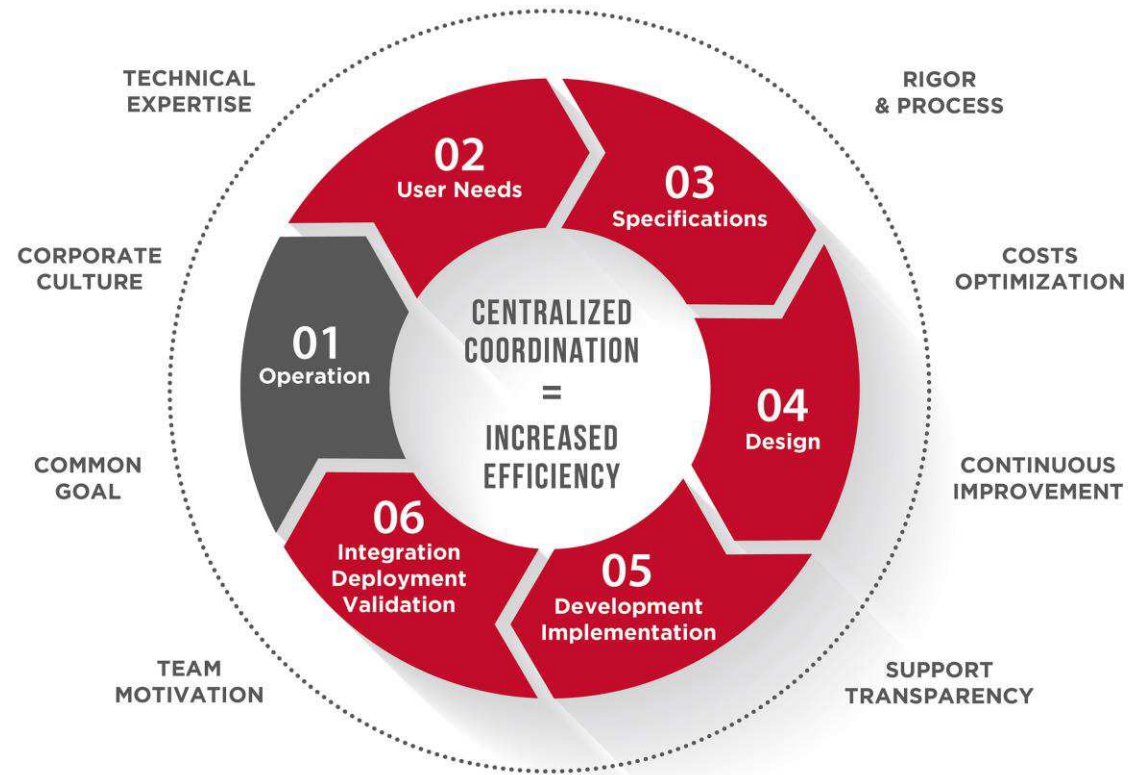

An indispensable approach in a changing space market, where the boundary between infrastructure and services tends to disappear.

Focus on Emergency Management & Disaster Resilience

Emergency Management & Disaster Resilience

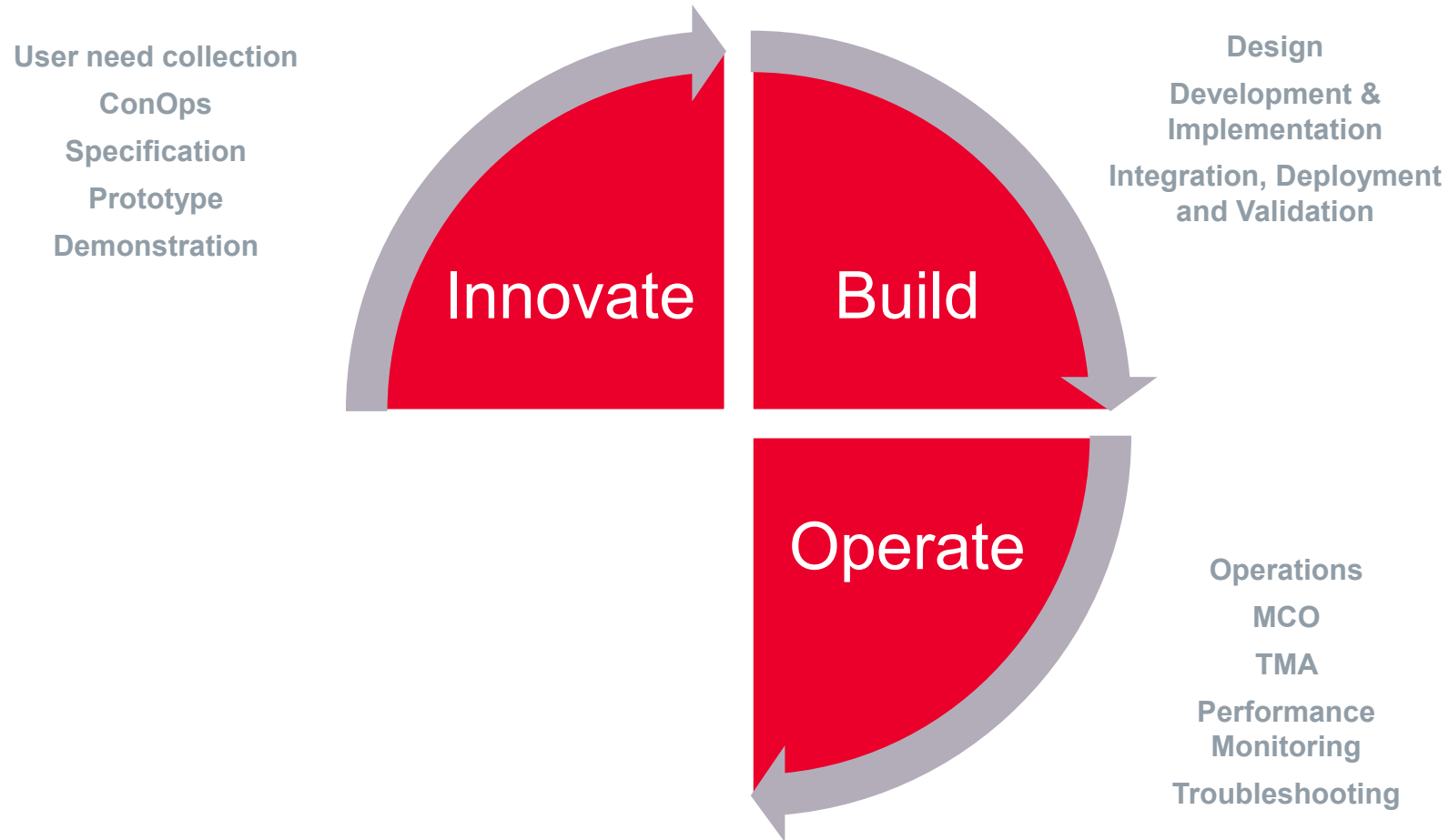

Emergency Management & Disaster Resilience

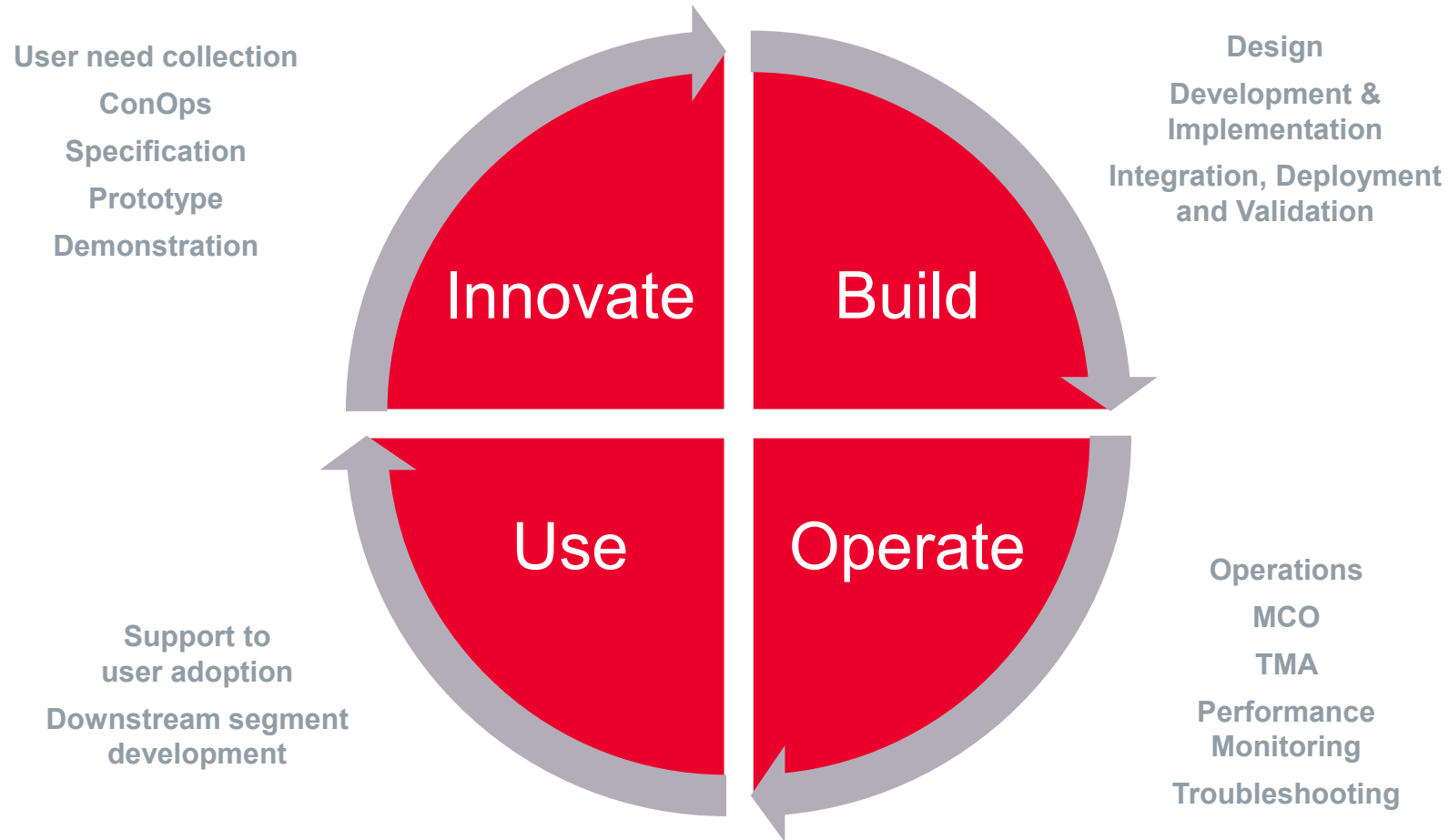

Emergency Management & Disaster Resilience

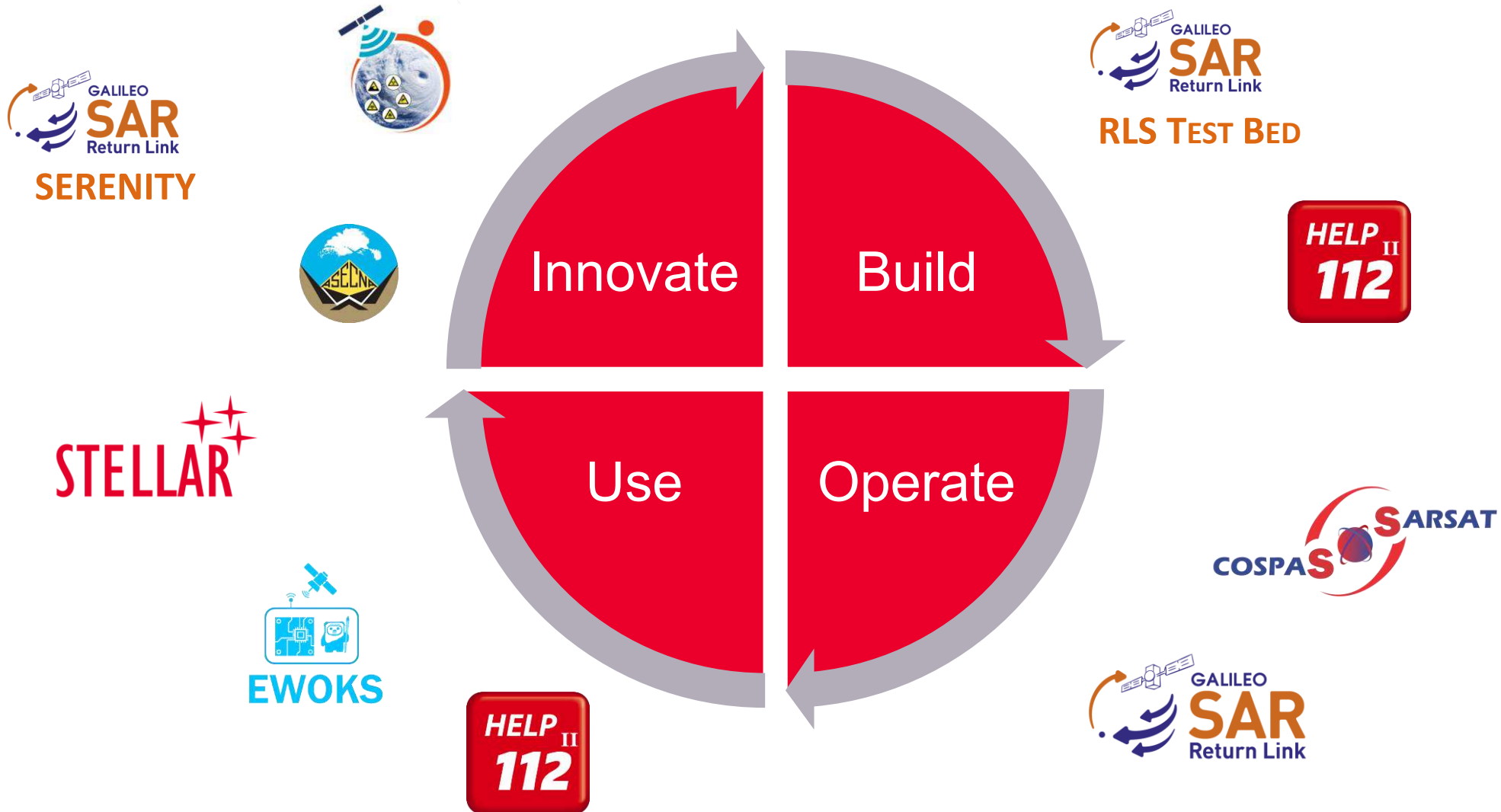

SAR



Need



CNES : Cospas-Sarsat, SAR/Galileo, RLS Test Bed
Support to Cospas-Sarsat and SAR/Galileo operation and engineering activities

European Commission : SERENITY
SAR/Galileo Two Way Communication service prototype & demonstration, Galileo Return Link service evolution

- Support Cospas-Sarsat and SAR/Galileo service provision
- Innovation & User Adoption

Activities



Cospas-Sarsat & SAR/Galileo (CNES, depuis 2018)

- Coordination of SAR/Galileo ground segment operation
- SAR/Galileo Service Center operation
- C/S French ground segment operation (FMCC)
- System monitoring and anomaly management
- Logistics
- Service Transition
- Performance monitoring

Return Link Test Bed (CNES, 2022)

- Design and development of the Return Link Test Bed, permanent platform for tests and demonstrations via Galileo Return Link

SERENITY (EC, 2021-2022)

- User need collection
- Specifications : Mission, Service and System
- Demonstrator : Design, Développement, IVV
- Demonstrations : Plan, Exécution, Report

Added Value



Cospas-Sarsat and SAR/Galileo Expertise
In-depth knowledge of downstream applications and services

Programme management and coordination with SLA

24/24 Monitoring, flexibility and adaptability

Operator vision : efficient, robust and optimized processes and methods

User proximity (e.g. SAR Force)

Clients & Partners



EWS



Needs



European Commission : GRALLE, STELLAR

- Definition, design and demonstrations of Galileo Emergency Warning Service (EWS)
- Support to Galileo EWS user adoption

ASECNA : Demonstration of a regional SBAS-based emergency warning service

EWOKS : Compatibility of fixed alerting devices with Galileo EWS

- Definition of public warning services based on GNSS and SBAS
- Innovation & User Adoption
- Development of downstream segment

Activities



GRALLE (CE/TAS, 2017-2018)

- Service Specification & Definition
- Operational Concept
- Prototype development, incl. smartphone app'
- Field demonstrations (France, Sicily, Australia)
- Cost-Benefit analysis

STELLAR (CE, 2021-2022)

- Galileo EWS operational concepts consolidation
- Demonstrator Development
- Execution of several demonstrations
- Other user adoption support activities

SBAS ASECNA (ASECNA/TAS, 2020)

- User terminal prototype to use SBAS L5 (GRALLE prototype upgrade)
- Development of an Emergency Warning Message generator (ASAP)
- Demonstration plan and execution

EWOKS (Horizon Europe, 2022-2024)

- Galileo EWS module development
- Indoor Warning System development
- Demonstration coordination

Added Value



Expertise on Galileo EWS and public warning systems (PWS)

Management and Coordination of European projects

Proximity with actors from the whole operational chain up to final users (e.g. Alerting Authorities)

Clients & Partners



Emergency Management & Disaster Resilience



Infrastructure Monitoring : High Performance InSAR Map Service for risk prevention & post-crisis monitoring

ALPES MARITIMES InSAR Map from TPZF “Mirror” EGMS Service

- European Ground Motion Service from Copernicus operational from mid-2022
- InSAR analysis from Sentinel-1

- « EGMS Mirror » Motion Map on Alpes Maritimes area elaborated by Telespazio France
- Improved performances thanks to high resolution data from COSMO-SkyMed (2015-2021)

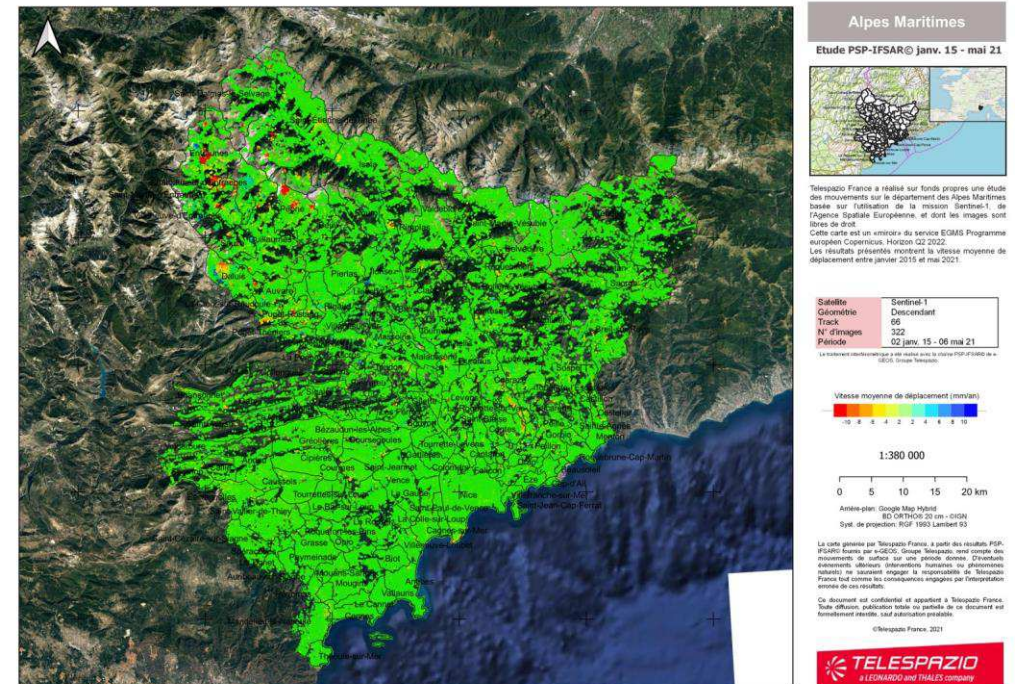

Emergency Management & Disaster Resilience



Managed Satellite Connectivity Service for PPDR - Public Protection and Disaster Relief

UGAP (France)



ASTRID (Belgium)



Praesens (Kenya, Senegal, Rwanda)
Mobile and autonomous medical laboratory for rapid deployment in areas regularly affected by epidemic and endemic disease





THANK YOU
FOR YOUR ATTENTION

axelle.pomies@telespazio.com



GNSS expertise in engineering, development, performances, operations and maintenance

Projet & Contract Mgt

Service Definition & Design

Architecture system

Conops Operations

Integration, Validation, Verification and Qualification

Hardware & Software Maintenance

GNSS Hosting sites services

Cybersecurity

RAMS/PA

CUSTOMERS



112



Besoin



Commission Européenne : HELP112 I & II
Assess/Demonstrate/Deploy Emergency caller handset-derived location

WorkingAge : Développement d'un système visant à améliorer la santé et le bien-être au travail, par la supervision des conditions de travail par capteurs et la fourniture de recommandations via une application mobile

Réalisation



HELP112 I & II (EC, 2015-2020)

- Assess & Demonstrate Emergency caller handset-derived location solutions (GNSS, Wi-Fi, Cell-ID)
- Advanced Mobile Location deployment in 7 EU Member State



WorkingAge (H2020, 2019-2022)

Développement de deux fonctionnalités de l'application en tâche de fond :

- Positionnement de l'utilisateur (intérieur/extérieur) basé sur du GNSS et Wi-Fi
- Fonctionnalité d'urgence, déclenchée manuellement ou automatiquement, permettant un appel au 112 et l'envoi de données-clés aux services d'urgences (architecture compatible du standard PEMEA)

Valeur Ajoutée



Expertise dans les communications d'urgence

Management et Coordination de projets européens

Proximité avec les acteurs de la protection civile européens, et internationaux

Clients & Partenaires



EWS enabled LRAD (EWSeLRAD)



Genasys™

Our view

EWS enabled LRAD (EWSeLRAD)



Genasys™

Contact our project team:

Financial contact: Isabel Sancho adm.ewselrad@genasys.com

Project Management: Carlos Escarpa pm.ewselrad@genasys.com

Technical Contact: Carlos Escarpa tec.ewselrad@genasys.com

Long Range Audio Devices (LRAD)

Devices for every necessity



Genasys' Emergency Management (GEM)

- Public Warning System
- Multichannel
- Multilayered

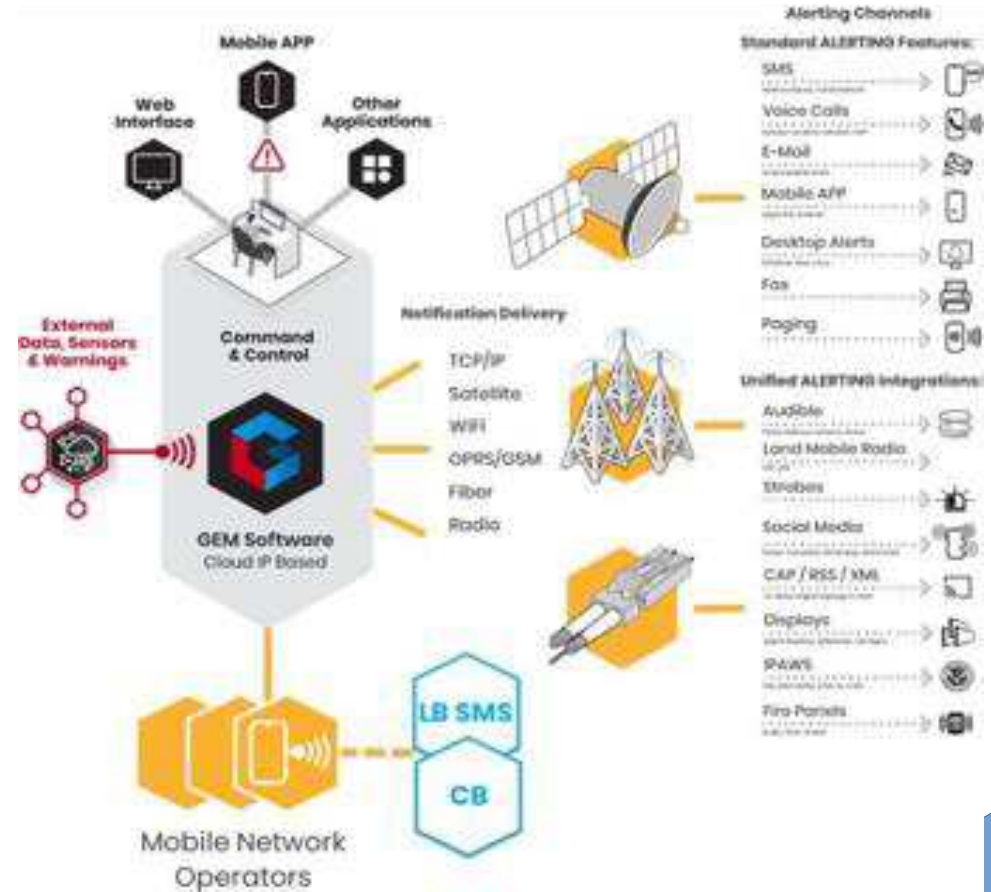

EWS enabled LRAD (EWSeLRAD)

- Public Warning System
- Triggered by Galileo's EWS signaling
- Decentralized control
- Autonomous deployment
- Global coverage

End to End use case

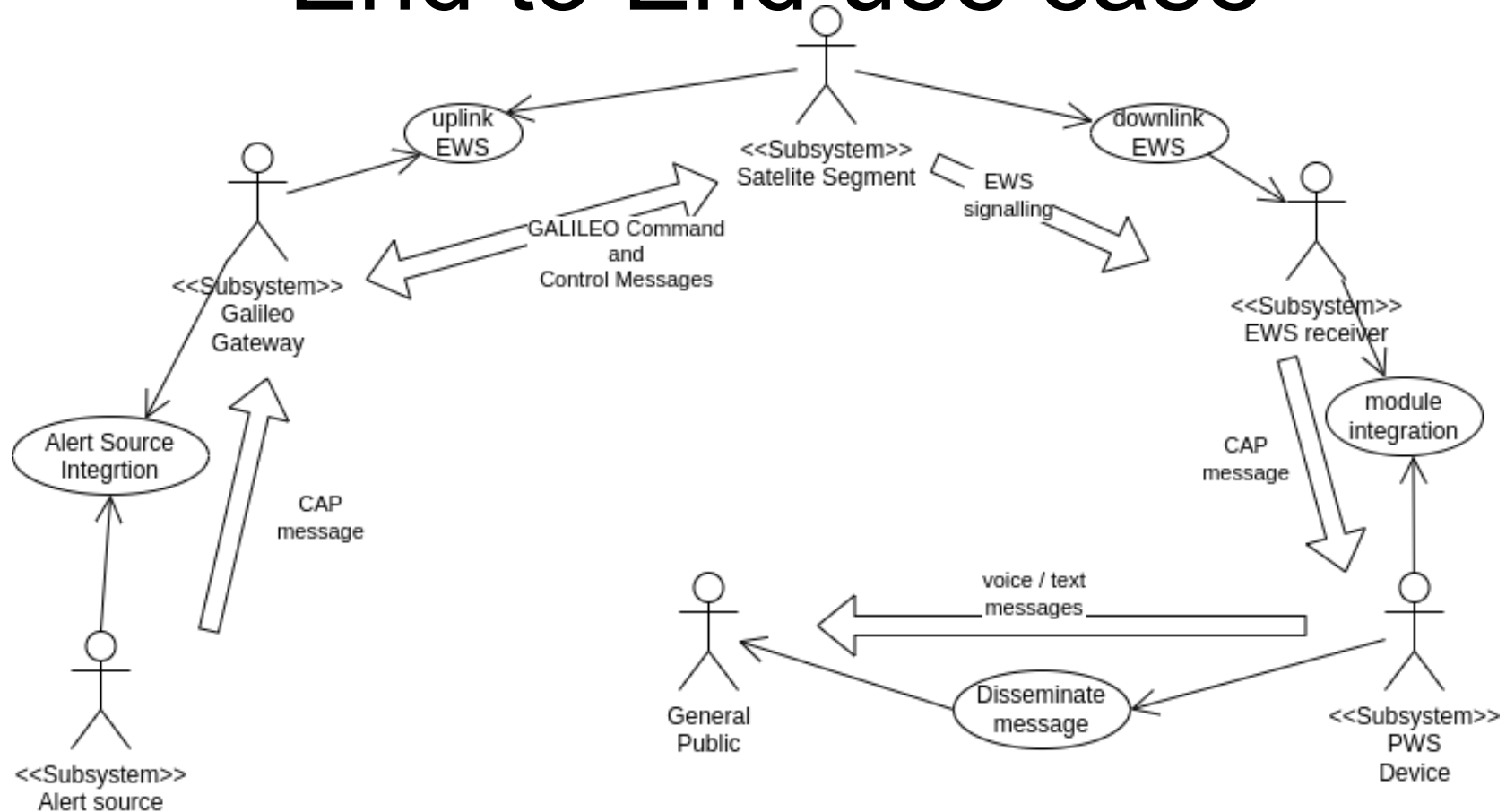

Genasys' fit in the overall use case

- Extend GEM to be an EWS compatible alert source, adding EWS to existing PWS dissemination channels.
- Enable LRAD deployments to process EWS messages by integrating an EWOKS module.
- Disseminate CAP messages as spoken alerts.
- Log and report EWS activity in a PWS system.

Alert Source integration

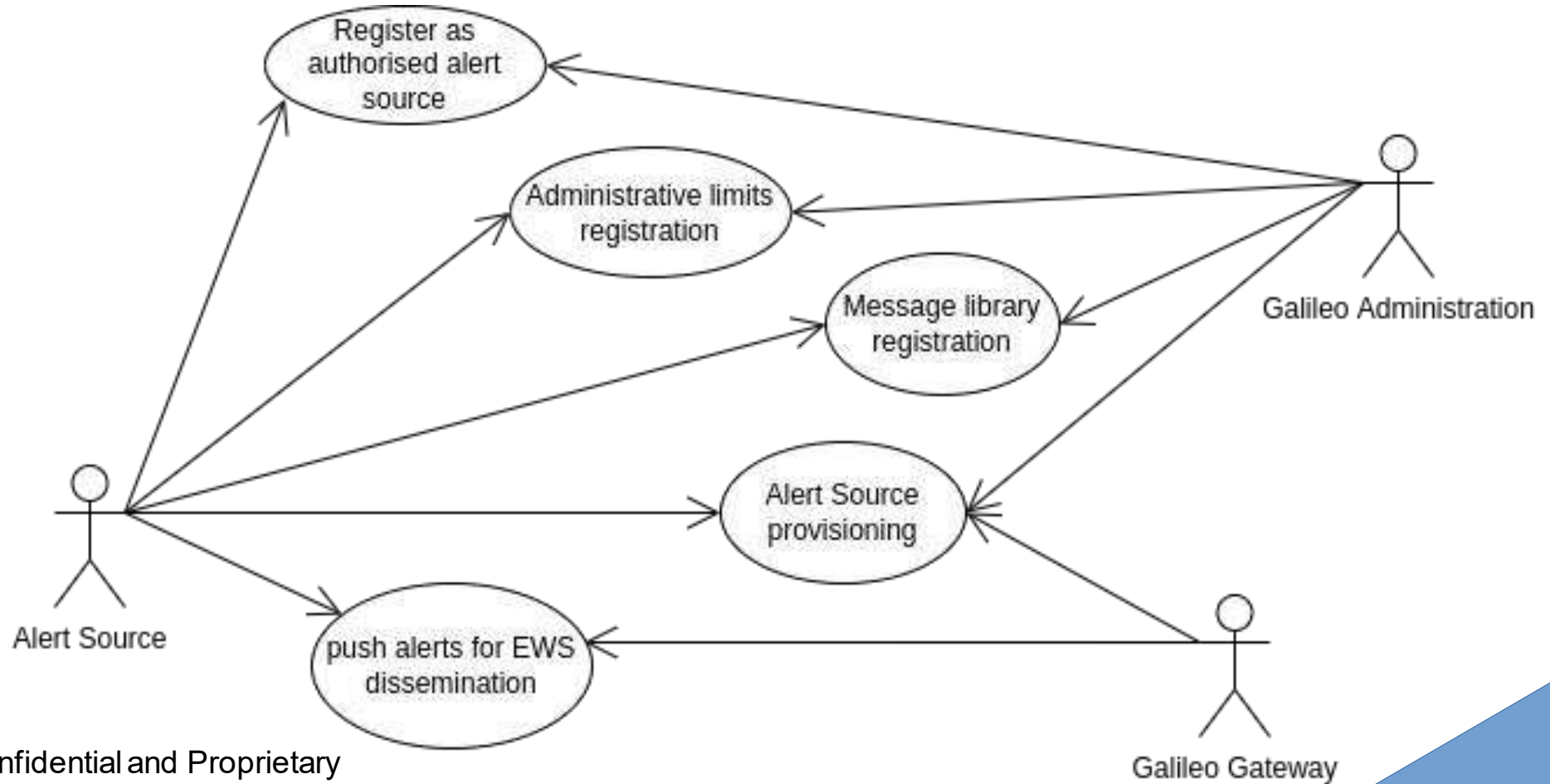

Alert source integration key points

Galileo gateway Compatible CAP syntax messages

Predefined text libraries to overcome EWS size limitations

Administrative domains per source/country

Elliptical warning areas, from the source or converted at the gateway side?

Multiple languages within a country

Authorization & Authentication at the gateway

Possible Integration with COPERNICUS

Module integration

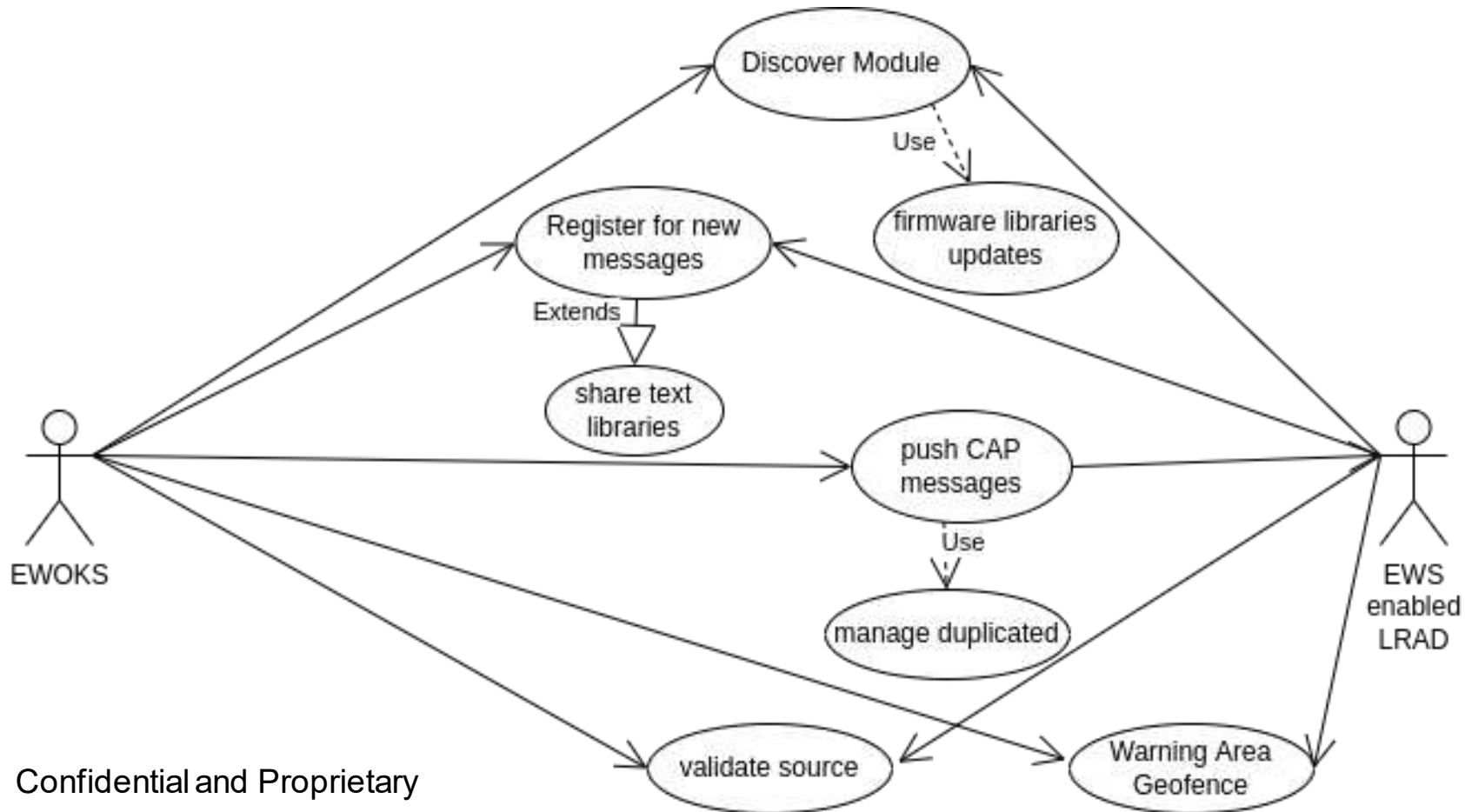

Module integration key points

Module connection, module discovery

Module firmware/libraries version & updates

Module / comms status reporting

Alert filtering (by administrative domains)

Alert filtering (by Warning Area Geofencing)

Alert filtering (deduplication)

Source validation (digital signatures?)

Message dissemination

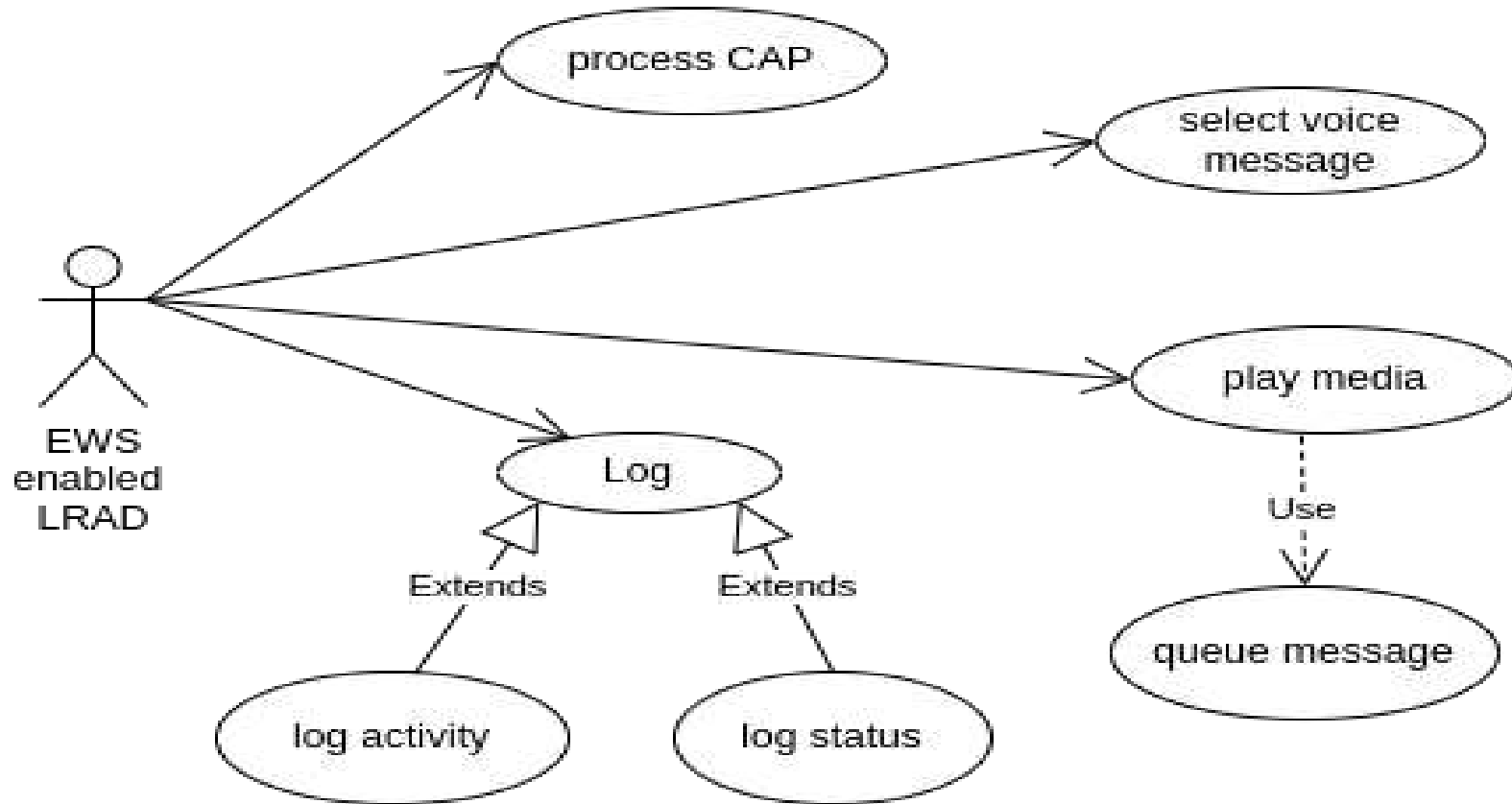

Message dissemination key points

Message libraries and pre recorded messages

Message queueing / priorities / preemptive reproduction

Message repetition

JCDecaux

EWOKS Kick Off Meeting: JCDecaux presentation

Praha – EUSPA – 7/12/22



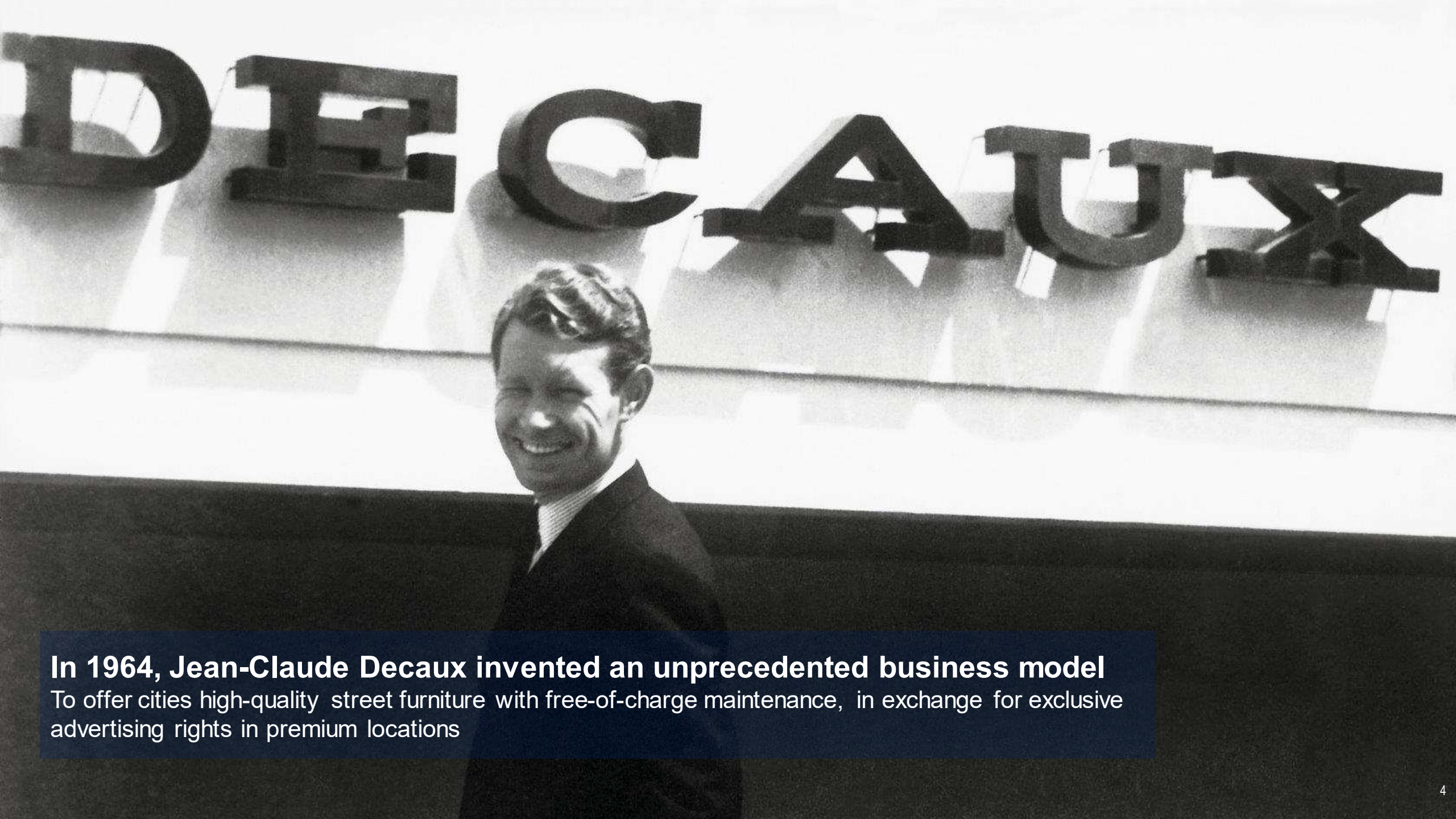

In 1964, Jean-Claude Decaux invented an unprecedented business model

To offer cities high-quality street furniture with free-of-charge maintenance, in exchange for exclusive advertising rights in premium locations

A VIRTUOUS MODEL AIMING AT SUSTAINABLY IMPROVING THE QUALITY OF LIFE IN THE CITY

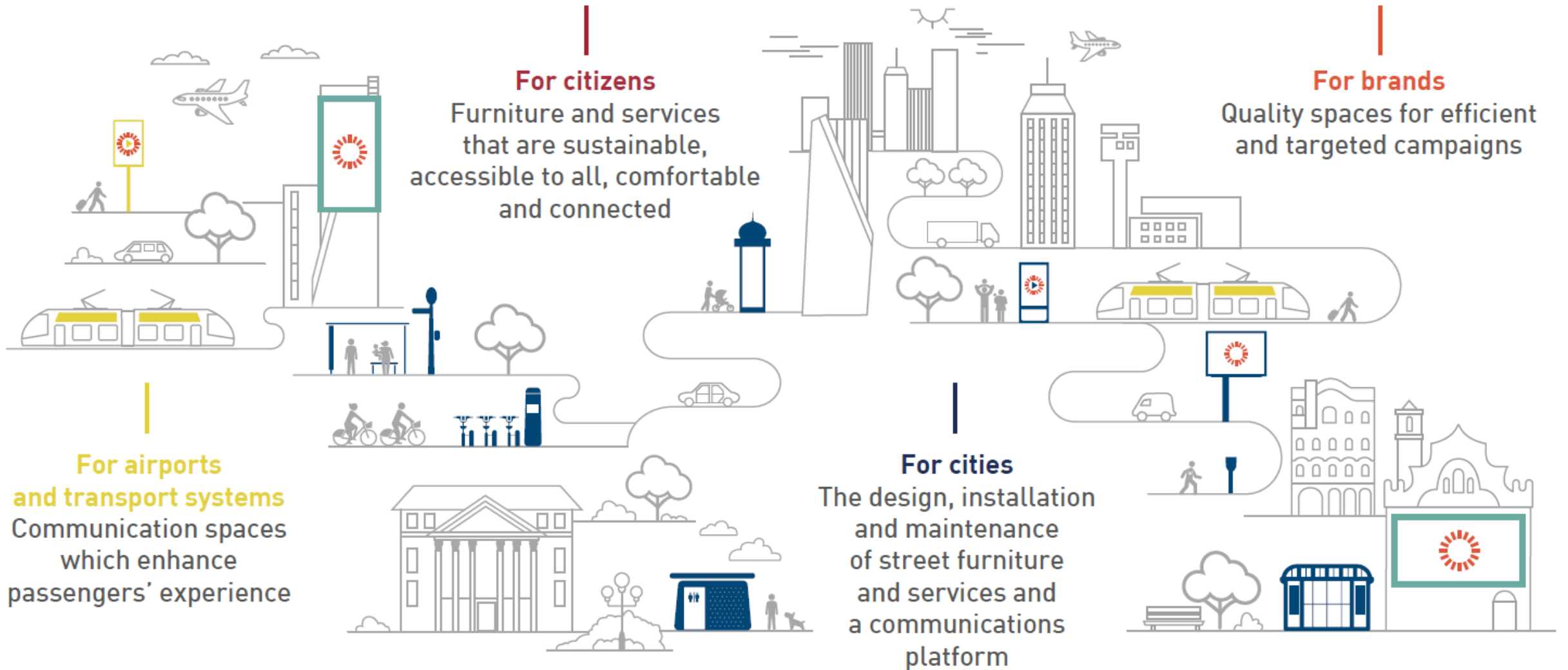

JCDecaux



From the outset, 2 indissociable dimensions

New services for cities and their inhabitants, as well as a new place for expression for brands

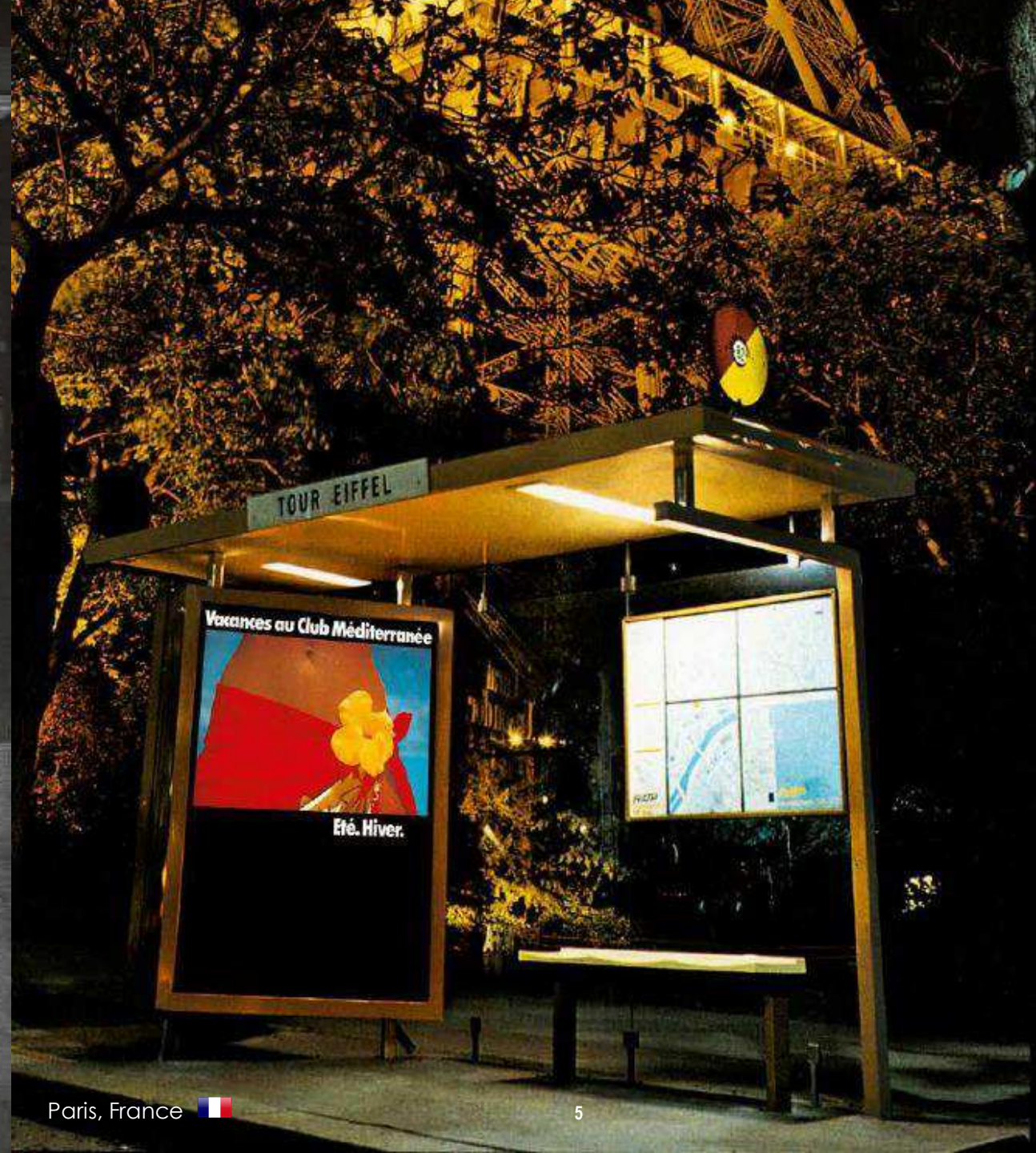

JCDECAUX AT A GLANCE

**NO. 1 WORLDWIDE
EXTERNAL
COMMUNICATION**
2021 revenue €2,745 million

3 ACTIVITIES

 **STREET FURNITURE**

 **TRANSPORT**

 **BILLBOARD**

IN +80 COUNTRIES



**No. 1
in Europe**
(593,831 advertising
faces)



**No. 1
in Asia-Pacific**
(232,268 advertising
faces)



**No. 1
in Latin America**
(64,893 advertising
faces)



**No. 1
in Africa**
(20,808 advertising
faces)



**No. 1
in the Middle East**
(14,177 advertising
faces)

10,720 employees

Presence in **3,518** cities with +10,000

ESG at the heart of the strategy
since its creation

Strong and innovative

Daily audience **+850 million**
people

957,706 advertising faces
worldwide

94 Global Top 100
advertisers

Solid financial structure

Most digitised OOH company, cutting-edge data
and programmatic expertise

INNOVATION: ANTICIPATION OF THE CITIES AND ADVERTISERS NEEDS

Almost 60 years of innovative services for all stakeholders

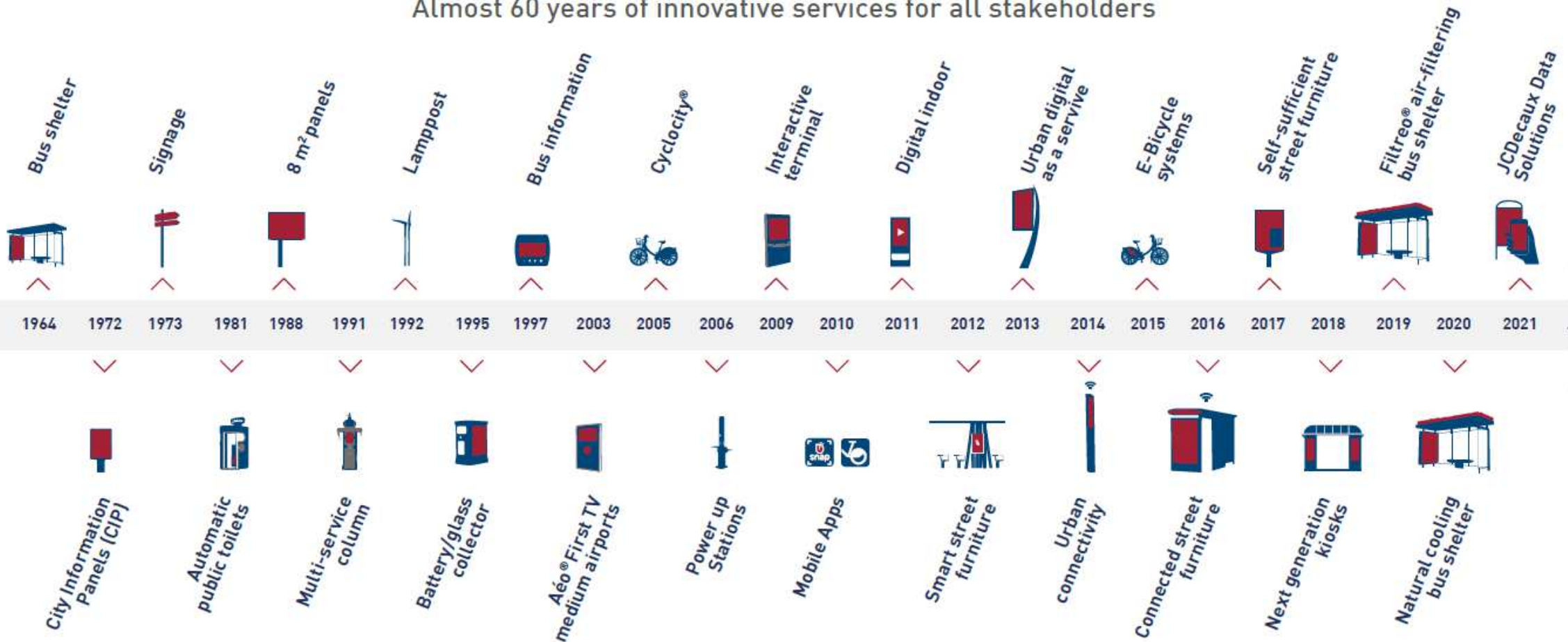

DIGITAL STREET FURNITURE



Digital street furniture, Amsterdam, Netherlands 

Adjusted figures

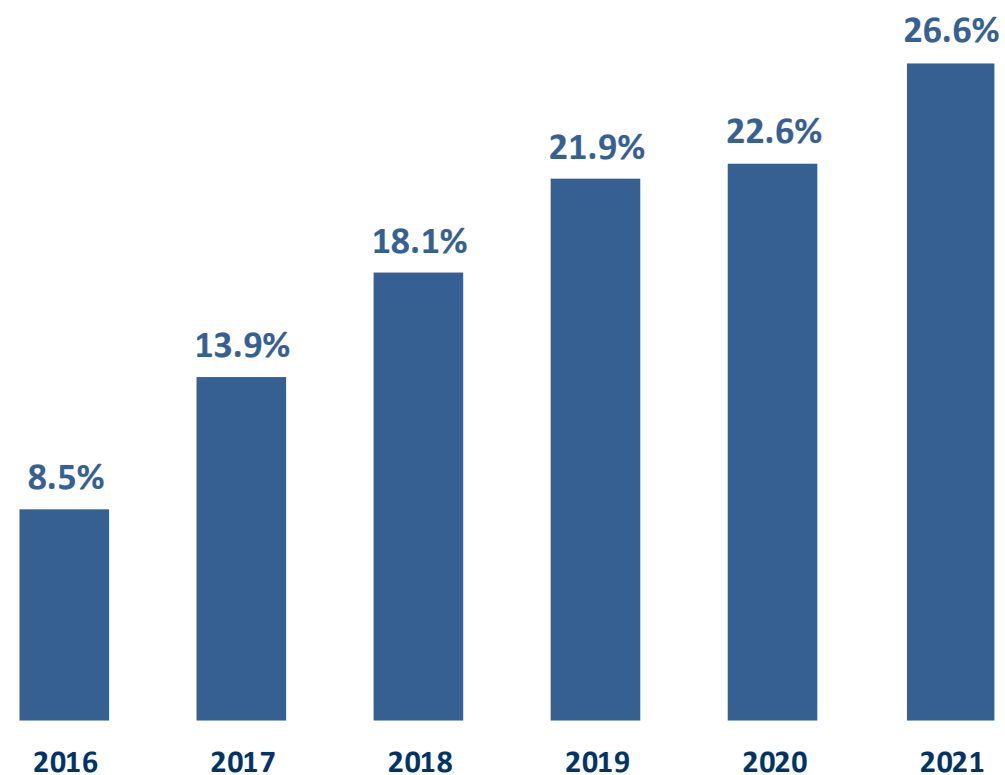

Street Furniture digital revenue as a % of total Street Furniture revenue

N.B.: Years prior to 2017 have not been restated from the IFRS 15 impact, applicable on January 1st, 2018.

Galileo Space Segment



EWS
Service center



EWOKS
Service Center



JCDecaux Ewoks Interface (hard/software)

- Communicate with EWOKS module
- Liaise with:
 - EWS Service center (warning DB)
 - EWOKS Service center (monitoring/update)
 - JCDecaux team for creation of display content (DB update)



Integrated in the Digital Panel

EWOKS GNSS Module
(Receive and process EWS
message)

EWOKS GNSS Module
(Receive and process EWS
message)

**Digital Panel with EWS
capabilities**

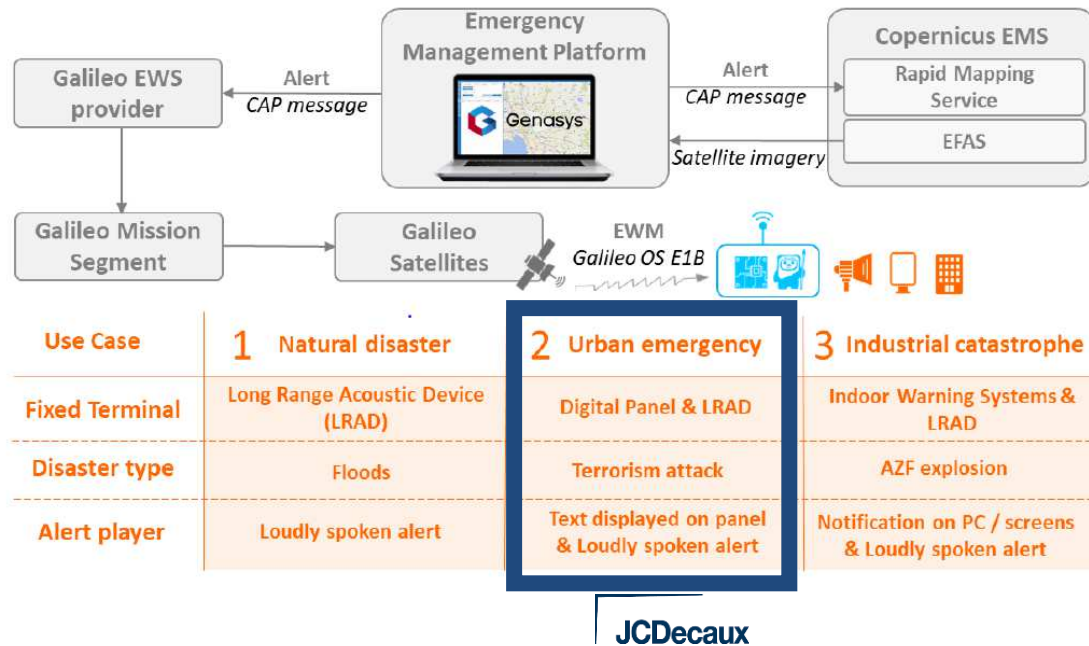



KOM EWOKS CNES presentation

07/12/2022

CNES overview

€ 2,4 billion
budget

2nd
World budget/inhab

80%
Goes to industry

PARIS (Les Halles) - 190 P

CNES headquarters

- Strategy,
- International relationships
- Administration



PARIS (Daumesnil) - 210 P

Launchers

- Study, design, development of launch systems (Ariane, Soyouz, Vega,)
- Preparing for the future

4 centres
2,400 employees



TOULOUSE - 1720 P

Toulouse Space Centre

- Study, design, development and control of orbital systems
- Digital technologies, data exploitation
- Preparing for the future
- Aire-sur-l'Adour : Balloons operation centre

GUYANE - 280 P

French Guiana Space Centre

- Ariane
- Soyuz
- Vega

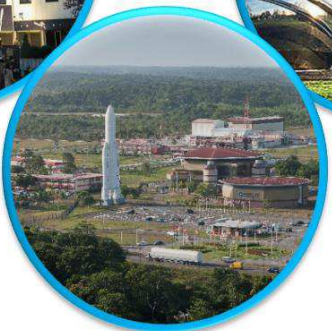

SAR Galileo Service Center (SGSC)

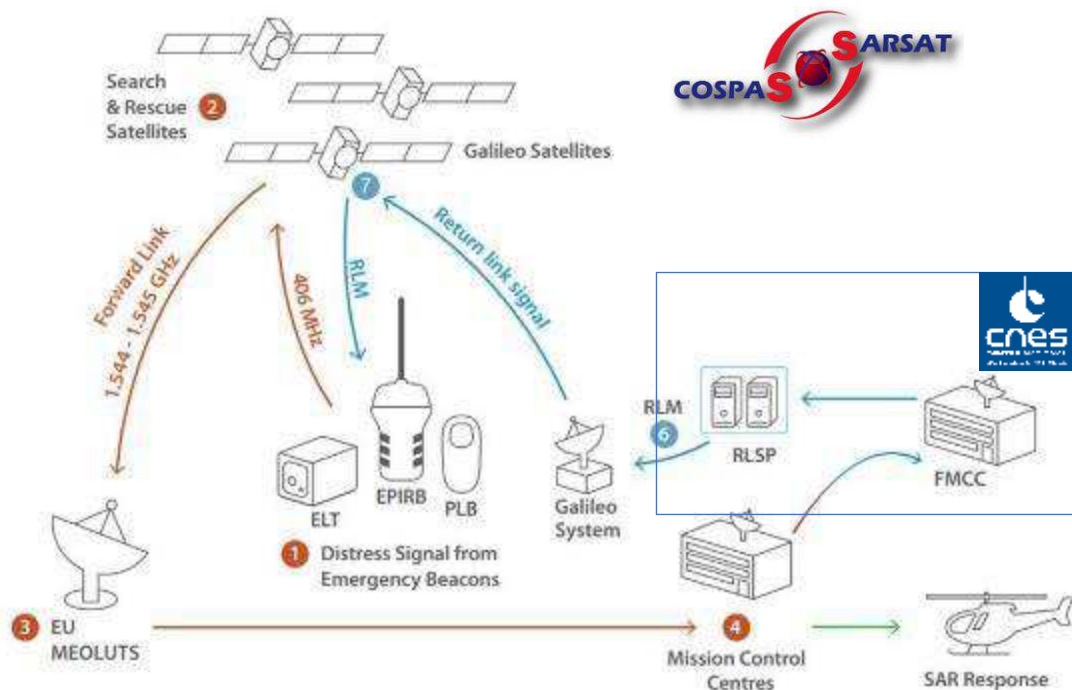

SAR/Galileo Data Service Provider

- Coordination of Operations & Maintenance
- Service Performance monitoring
- SAR/Galileo interface with the Cospas-Sarsat
- Technical support for the Service evolutions

EWS Service Provider

RLS Test-Bed (RTB) : EWS-RLSP interface

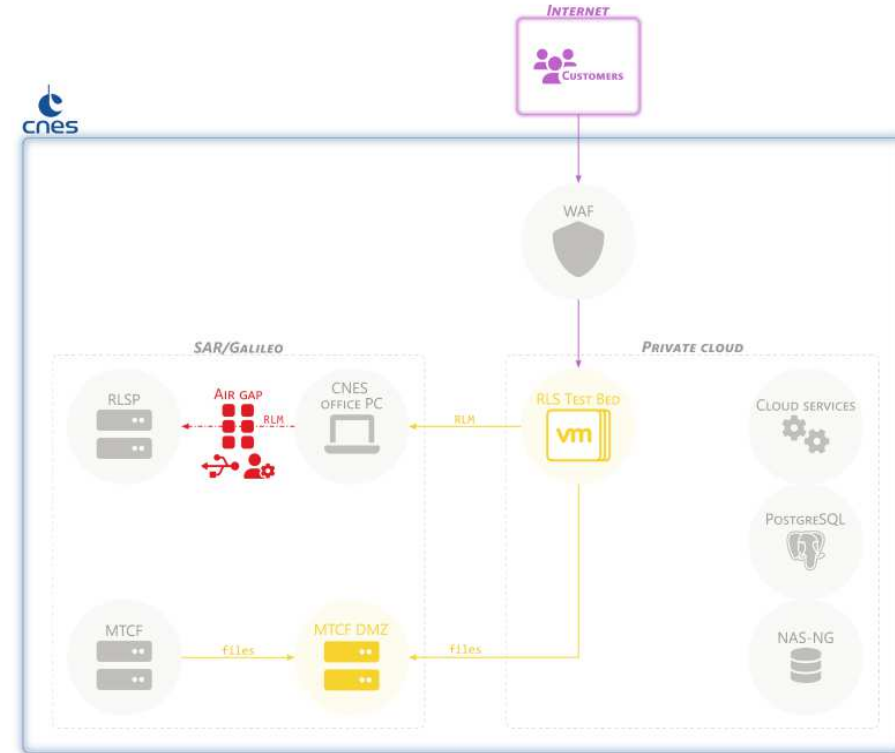
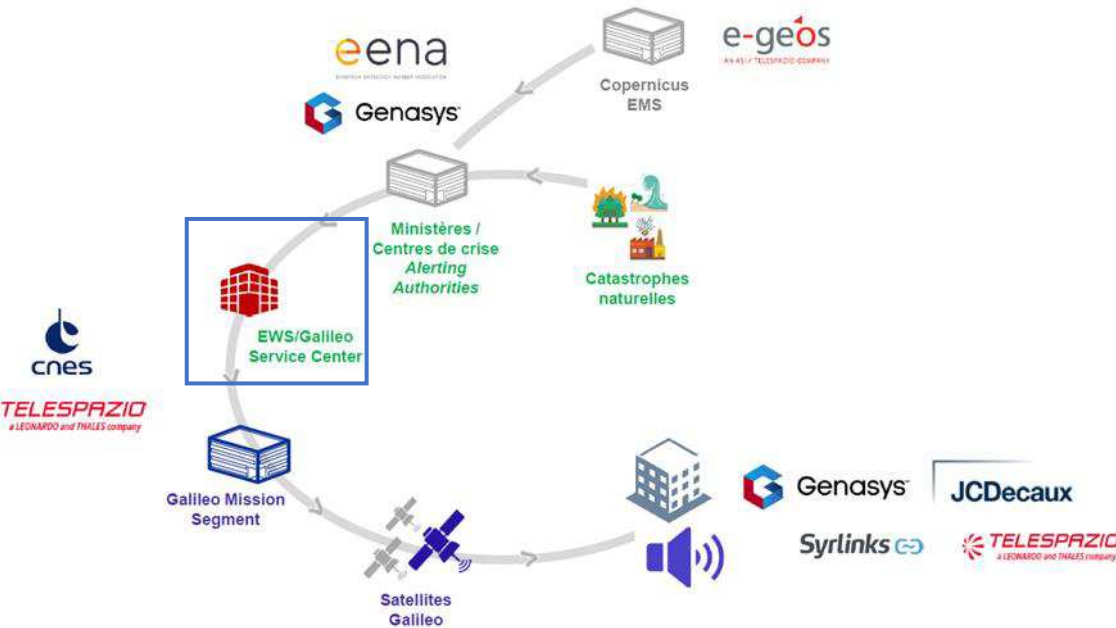

EWOKS WPs contibution

- **WP2: Support to concept definition for EWS Galileo service**

- **WP4: Support to integration and validation of EWOKS**

- **WP5:**
 - **Support to EWOKS demonstrations:** operational support and test plan/test report contribution

 - **WP5.1: Security analysis:** impact analysis on RLSP accreditation perimeter

Key personnel

- **Maaïke Doorn:** Legal/Contractual officer
- **Mathilde Dufour:** Technical Project Manager
- **Sylvain Delattre:** Project Manager
- SGDSP operational team
- SGDSP security team

EWOKS

HORIZON-EUSPA-2021-SPACE-02-52

EGNSS applications for Safety and Crisis
management

Enabling EWS/Galileo Market Uptake in
widespread PWS Solutions

SERTIT : SErvice Régional de Traitement d'Image et de Télédétection

Technological and service platform of ICube Laboratory
in University of Strasbourg

Valorisation and technological transfer in Space Techniques and Earth
Observation applications

Applications



Regional planning



Environmental studies



Natural resources
(vegetation, water,
biodiversity)

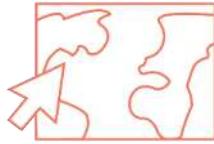

Natural disaster and
Risk Management

Services

- Specific R&D studies
- Expertise
- Assistance
- Geo-information prodction



24/7
Rapid Mapping
service

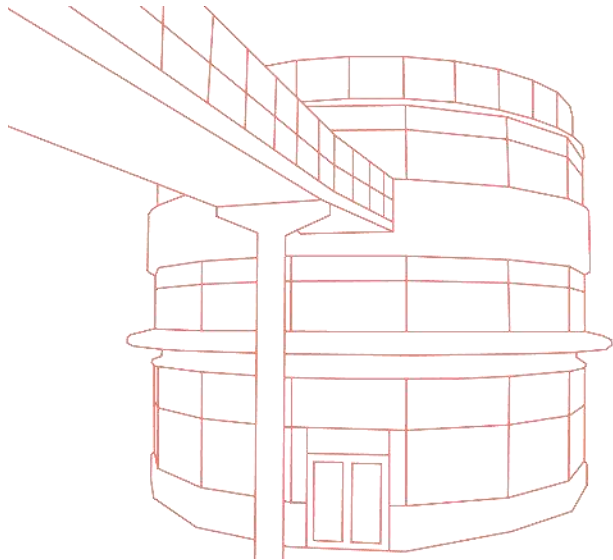

Professional team and resources

- 21 multi-disciplinary specialists
- Specialised up-to-date equipment
- Surrounding research laboratories

Video presentation of SERTIT:
<https://www.youtube.com/watch?v=umROJqgsk1Y>

Web site SERTIT: <https://sertit.unistra.fr/>

EWOKS – Why Us?

- EWOKS will also study, make recommendations and demonstrate **synergies** between Galileo EWS and Copernicus Emergency Management Service (EMS).
- UNISTRA will be in charge of this activity with the support of Telespazio

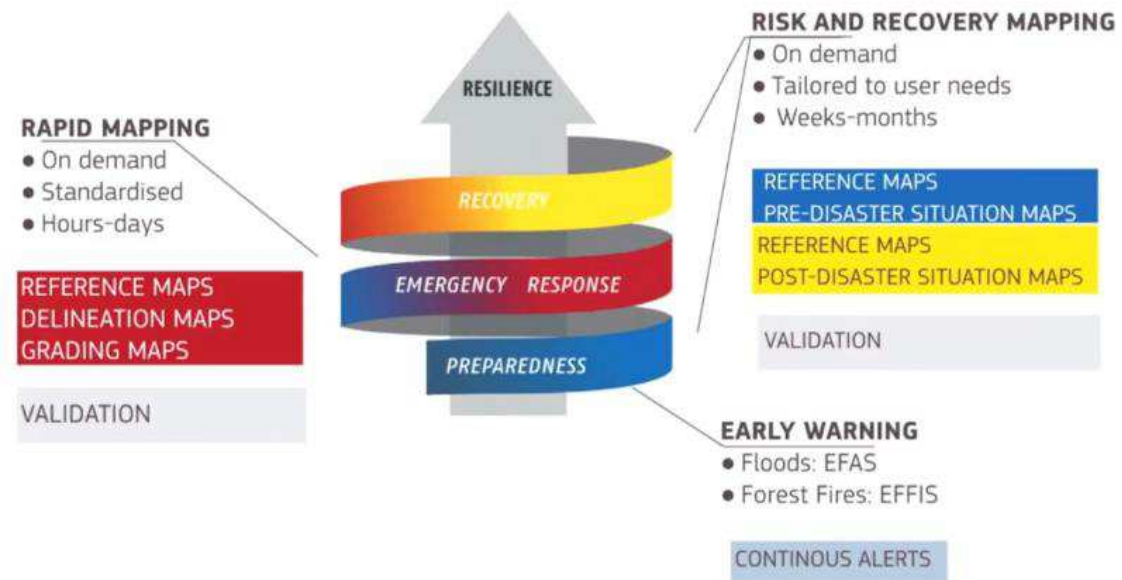

SERTIT's Rapid Mapping : 22 years of experience, multiple frameworks



... since 2015

Copernicus Emergency Management Service (CEMS)
 Contract management, Activation Management &
 Production Site



... since 2000

International Charter
 Space and Major Disasters

- Project Manager, Production Site, Capacity Builder
- Pléiades Value Adding Service
- Recovery Observatory

Insurance Sector

DESCARTES

...and other insurance industry players



SERTIT

RAPID MAPPING
 • On demand
 • Standardised
 • Hours-days

REFERENCE MAPS
 DELINEATION MAPS
 GRADING MAPS

VALIDATION



SERTIT

RISK AND RECOVERY MAPPING

- On demand
- Tailored to user needs
- Weeks-months

REFERENCE MAPS
 PRE-DISASTER SITUATION MAPS
 REFERENCE MAPS
 POST-DISASTER SITUATION MAPS

VALIDATION

EARLY WARNING

- Floods: EFAS
- Forest Fires: EFFIS

CONTINUOUS ALERTS

SERTIT



Copernicus EMS - Rapid Mapping

COPERNICUS
Emergency Management Service - Mapping

Home | What is Copernicus? | What is CEMS - Mapping? | Link to Early Warning Systems | News

LATEST NEWS - 2022-08-05 | [EMSN134] Forest fire in Carcastillo, Spain

EMS - MAPPING

- Who can use the service
- How to use the service
- Portfolio: Rapid Mapping
- Portfolio: Risk and Recovery
- Quality control
- User Guide

RAPID MAPPING

- List of Activations
- Map of Activations
- GeoRSS Feed
- Online Manual

RISK AND RECOVERY

- List of Activations
- Map of Activations
- GeoRSS Feed
- Online Manual

OTHER

- Map of Activations of Other Organizations
- Meetings, Workshops
- Citation Guidelines
- Citations
- Press Mentions
- Calls for Tender (NEWS)

Copernicus Emergency Management Service - Mapping
A service in support of European emergency response

Map above displays only latest Copernicus EMS - Mapping Activations. To see a Map of All Activations, go to section Map of Activations in Rapid Mapping or in Risk and Recovery Mapping sub-menus respectively.

Act. Code	Title	Act. Date	Type	Country/Terr.	Feed
EMSR630	Wildfire in Harz region, Germany	2022-09-04	Wildfire	Germany	
EMSR629	Floods in Pakistan	2022-08-29	Flood	Pakistan	
EMSR628	Forest fire in Samardá - Vila Real,...	2022-08-22	Wildfire	Portugal	
EMSR627	Wildfire in Orkeny, Hungary	2022-08-22	Wildfire	Hungary	

Standardisation

- Authorised Users
- 24/7 on-call
 - Satellite image provision
 - Rapid mapping team (OdO + PS)
- Map types and content specifications
- Free Delivery to All (Web)
- Validation, both formal and scientific

➤ Advantage: In this context a consortium can easily work together

Service Provider : e-GEOS, SERTIT, GAF, ITHACA, CLS, TPZ IB, GMV

Pre-alert / pre-tasking helps a lot

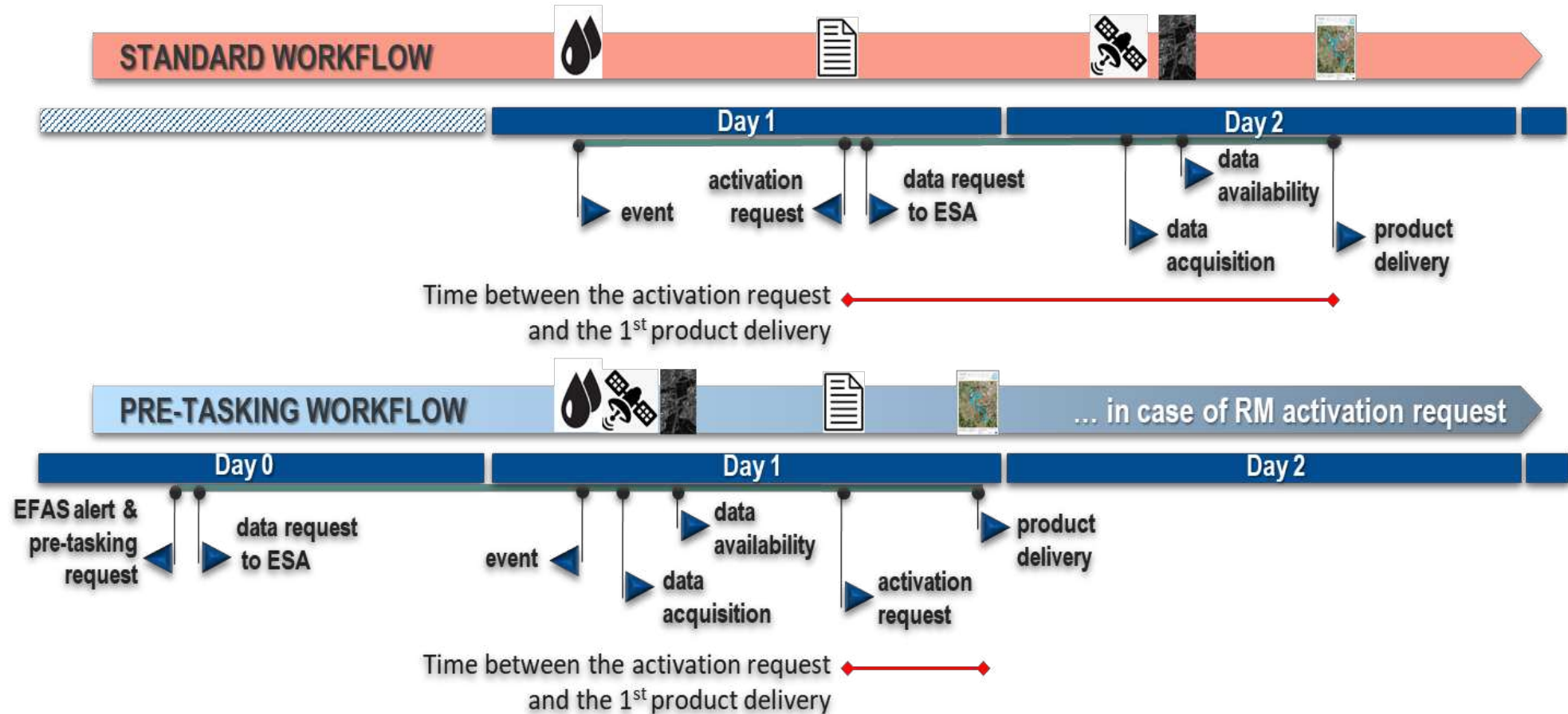

Tasks

WP2 - Product & Service Specification and Design

- Task 2.3 To support EC and EUSPA on the definition of advanced concepts for Galileo EWS evolutions (TPZF, EENA, SYR, UNISTRA) and to make the link with CEMS stakeholders.
- Task 2.4 To liaise with EWS/Galileo operational entities, in order to ensure a smooth integration into the Galileo EWS service (TPZF, SYR, CNES, UNISTRA) and to make the link with CEMS stakeholders

WP4 - EWOKS Integration and validation

- Task 4.6 To integrate and validate the E2E service using EWOKS enabled devices (TPZF, all)
 - To validate the effective integration of CEMS requirements in the EWOKS system

EWOKS Demonstration

Exploitation and Dissemination

AWARE

enAbling eWs gAlileo maRket uptake in widEspread pws solutions

Delat Kick-Off meeting with EUSPA



REPUBLIC OF SLOVENIA
GOV.SI

REMOTE

8 November 2023

AGENDA

- Short introduction of reviewers (Juan Luis Valero, Doug Watson)
- Brief presentation of the updated project (TPZF)
- Presentation FDC and tasks led by FDC (FDC)
- Update on Galileo EWSS (EUSPA)



Short introduction of reviewers



Brief presentation of the updated project



AWARE vs EWOKS project

- Same objectives
- Same tasks
- FDC in replacement of SYRLINKS
- Main partner role evolutions:
 - TPZF becomes Prime
 - FDC replaces SYRLINKS on the exact same technical perimeter



AWARE (ex-EWOKS)

Slide added after the meeting

- Co-funded EUSPA Horizon Europe project led by Telespazio France
- Main objective : development of a Galileo EWSS solution for fixed Public Warning Systems such as sirens, long-range acoustic devices, digital panels or indoor alerting devices
- Budget : 3,5m€ / Grant : 2,6m€
- HORIZON-EUSPA-2021-SPACE-02-52 : EGNSS applications for Safety and Crisis management



Objectives

- To develop a Galileo EWSS module
- To demonstrate the whole chain on various use cases :
 - « Natural disaster » with an upgraded **Long-Range Acoustic Device - LRAD**
 - « Urban Emergency » with an upgraded **Digital Panel - DP**
 - « Industrial Catastrophe » with a fixed receiver on the roof connected to IT system - **Indoor Warning System - IWS**
- To prepare Galileo EWSS user uptake
- To provide feedback on advanced Galileo EWSS Service Concepts
- To analyse and demonstrate synergies btw Copernicus EMS and Galileo EWSS

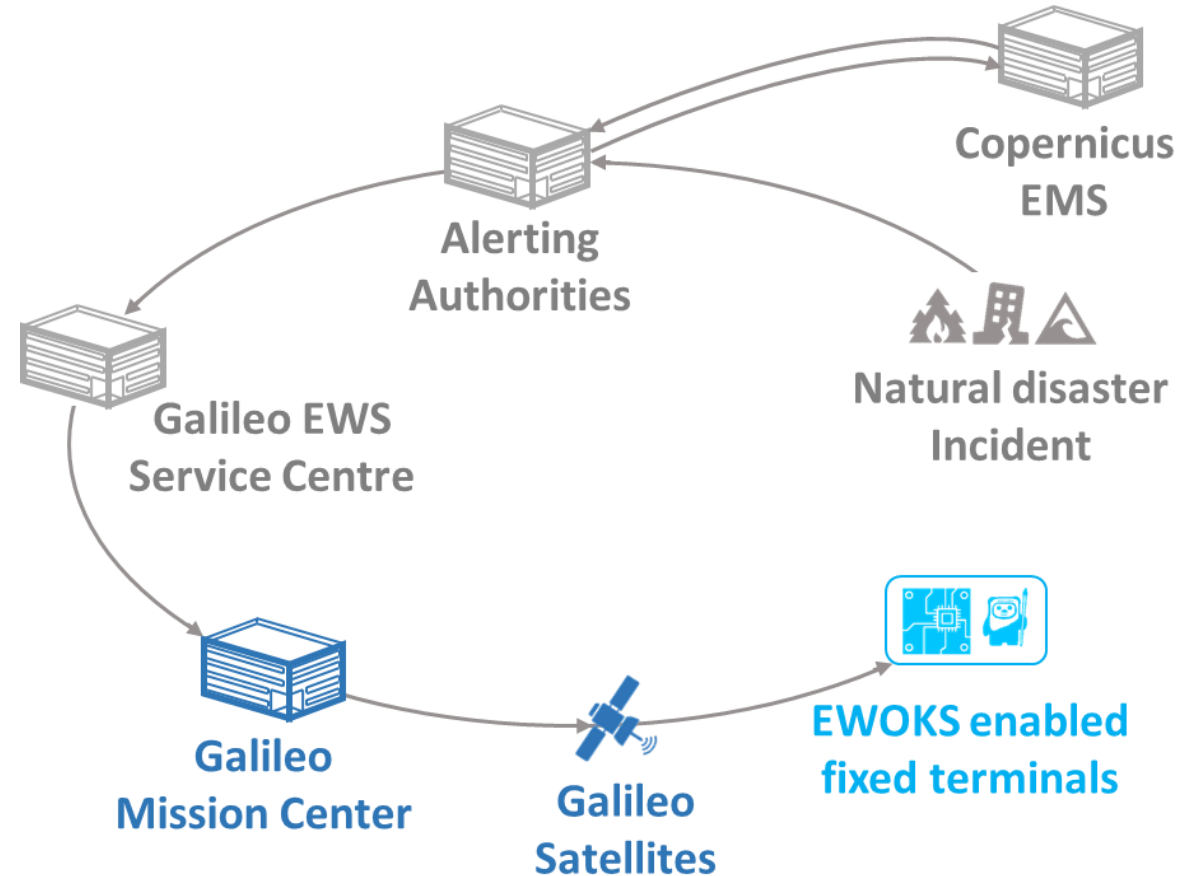

AWARE vs EWOKS WBS

EWOKS

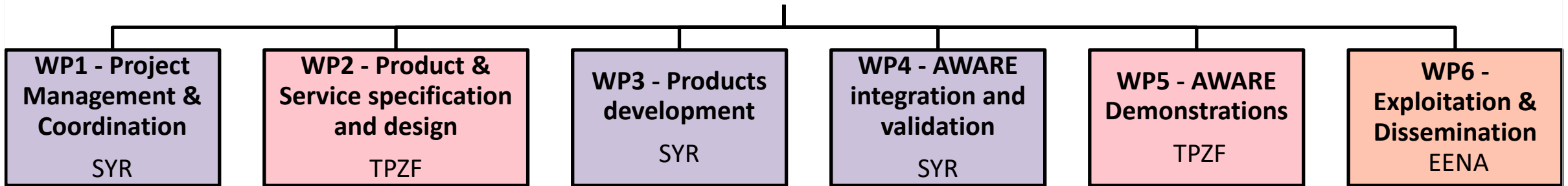

AWARE

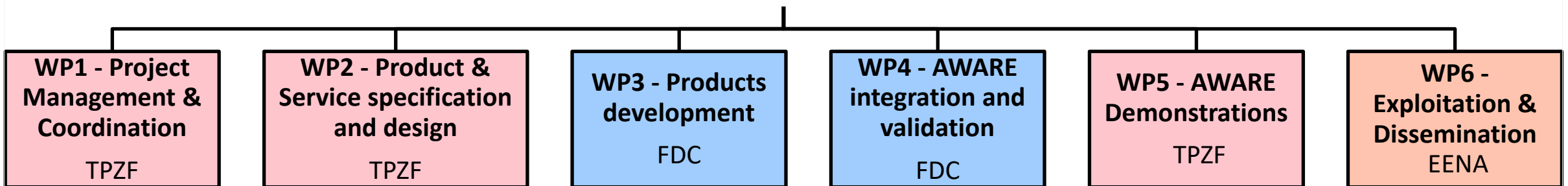

AWARE Consortium Partners : Main roles

- **TPZF** : Prime, System Engineering, AWARE EWSS SW development, Demonstration Lead, AWARE Module integration in IWS
- **FDC** : AWARE Module Manufacturer, System IVV Lead
- **Genasys** : Alert platform provider, AWARE module integration in LRAD
- **JC-Decaux** : AWARE module integration in DP
- **CNES** : Operations for end-to-end Demonstrations
- **UNISTRA** : Analysis and demonstration of synergies between Copernicus EMS and Galileo EWSS
- **EENA** : Representative of Alerting Authorities, User needs collection, Support to Dissemination/Awareness
- **Slovenian Civil Protection** : Involvement in Demonstration



REPUBLIC OF SLOVENIA
GOV.SI

AWARE Consortium Partners on the operational chain

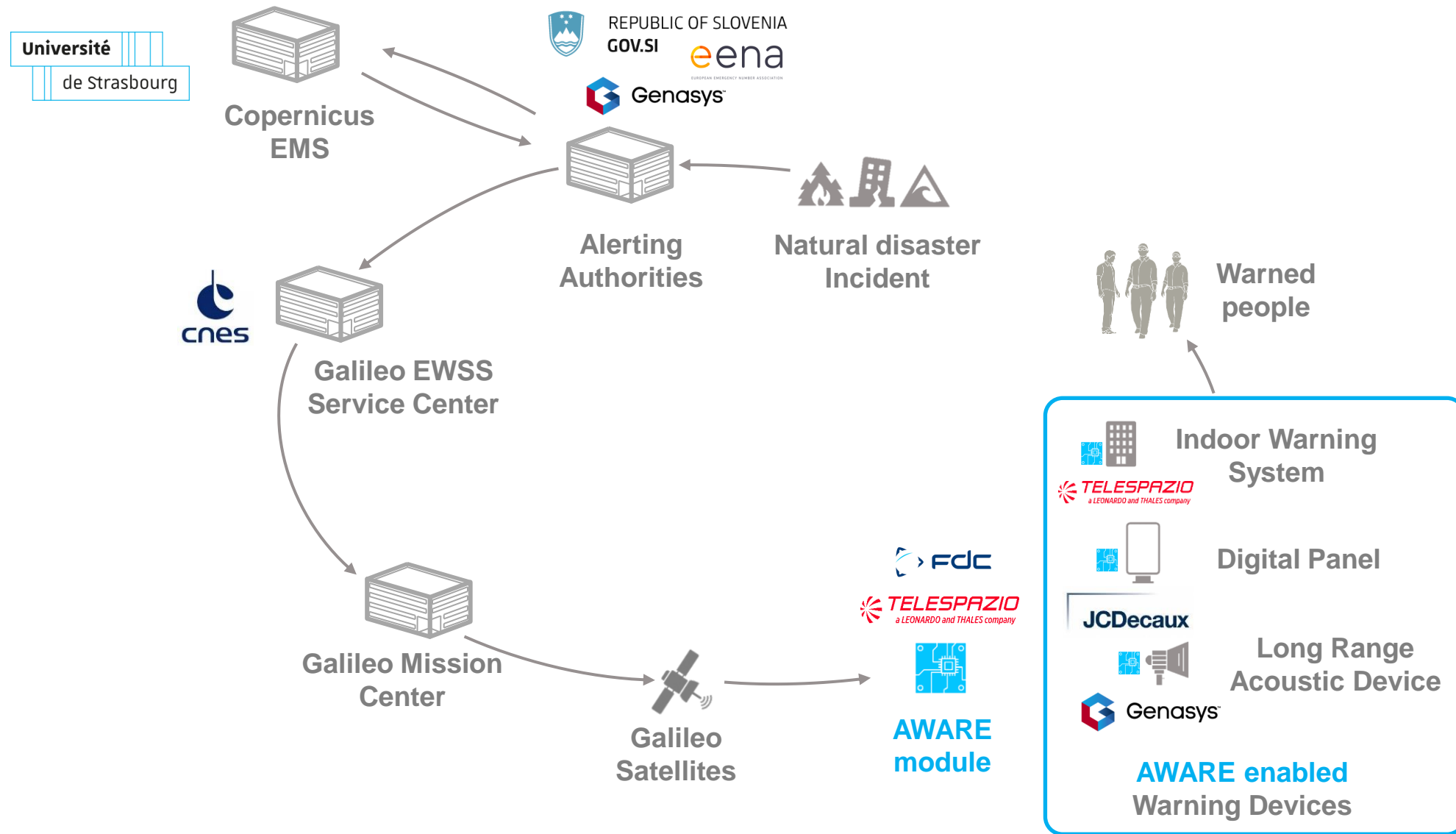

AWARE

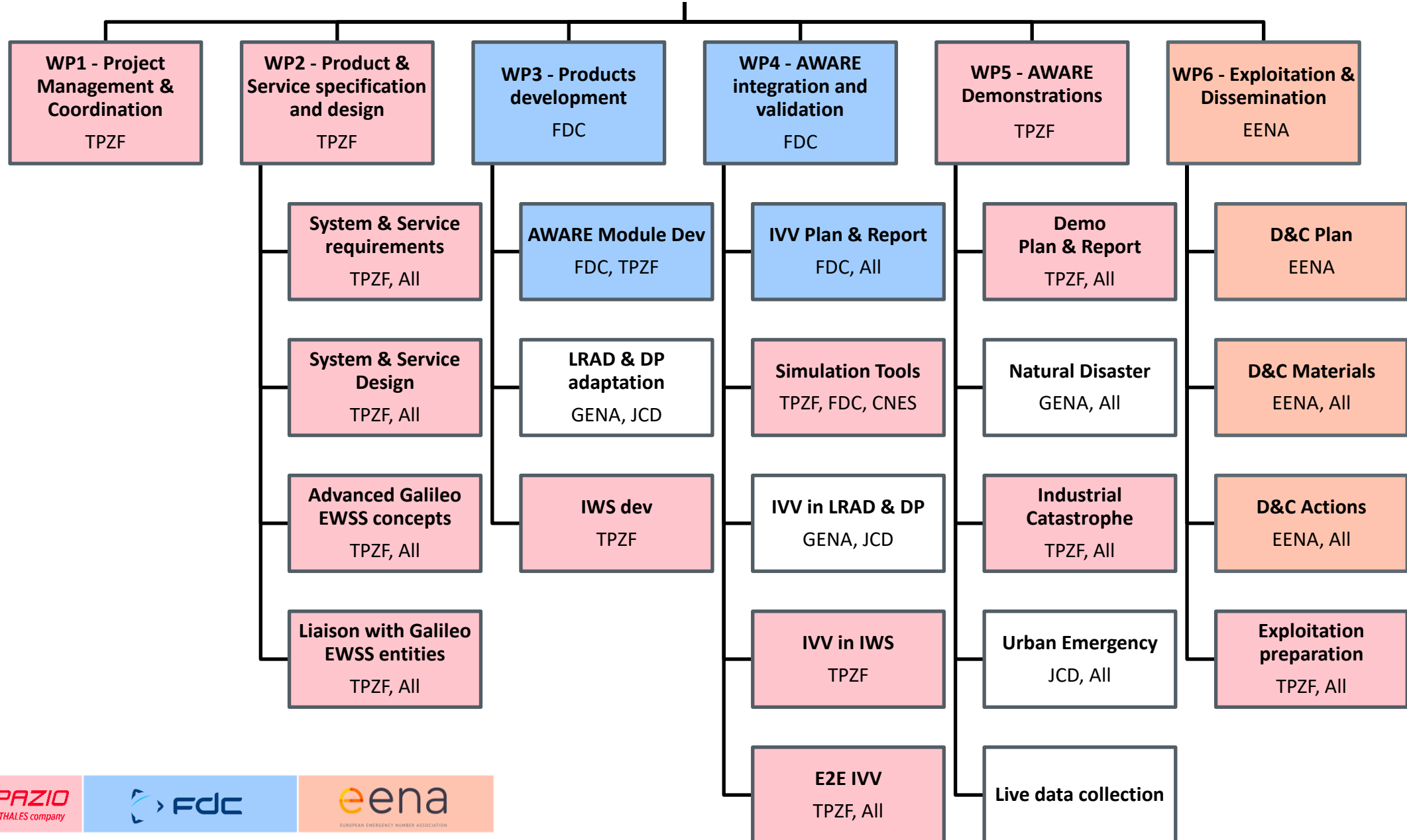

Master planning (under consolidation)

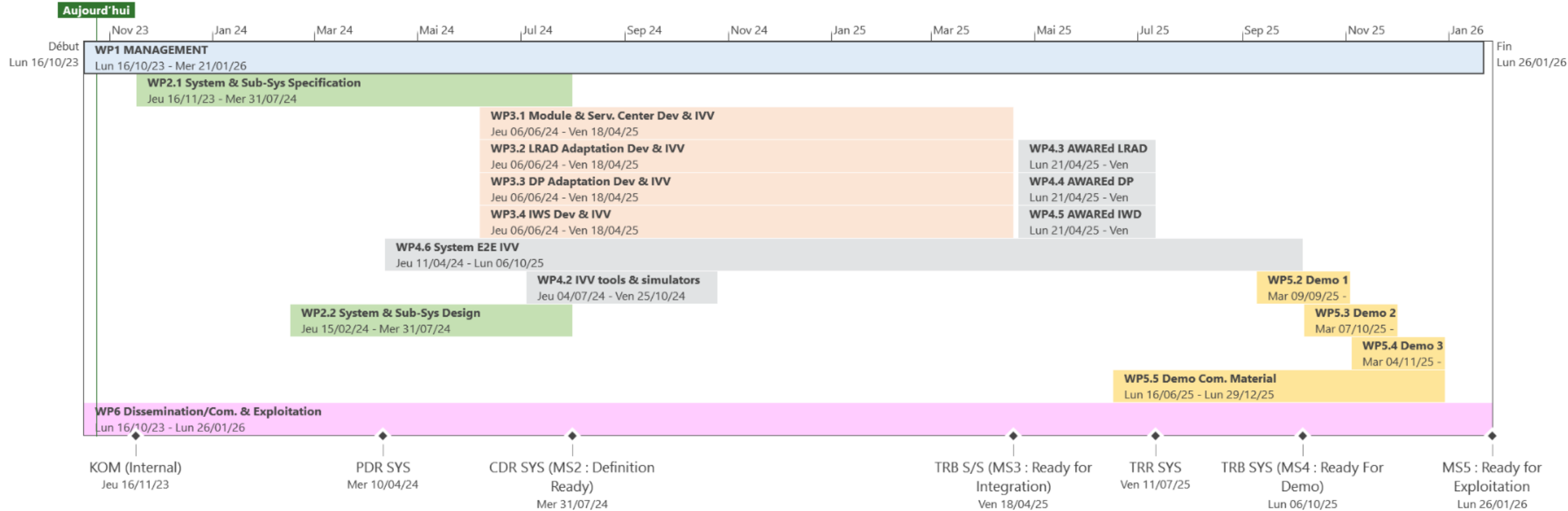

Specification phase extended to leave enough time to conduct preliminary market/user survey



Master planning – Open questions

- Actual T0 for the system ???
 - T0 : 1 Nov 2022
 - Suspension date : 23 Jan 2023 (~3 months from T0)
 - Resuming date : 16 Oct 2023

- Potentially impacted deliverables in the short term
 - D1.3 Project Management Plan (M1)
 - D1.6 Data Management Plan (M2)
 - D2.1 Initial AWARE Requirements Specification (M3)
 - D6.1 Initial AWARE Dissemination and Communication Plan (M3)

- Is a formal process required to postpone deliverables due date ?
- Is a formal process required to extend the specification phase ?



Contractual Milestones

Milestone number	Milestone name	Related work package(s)	Due date (in month)	Due Date	Means of verification
MS1	Kick-Off	All	M1	07/12/2022	Minutes of Meeting, GA, CA signed
MS2	AWARE Definition Ready	WP2, WP4	M9	07/2024	D2.1, D2.2 agreed by all participants
MS3	AWARE Ready for integration	WP3	M18	04/2025	All D3.x s subsystems ready for integration
MS4	AWARE Ready for Demonstration	WP4, WP5	M24	10/2025	D4.3 Validation report
MS5	AWARE ready for Exploitation & Final Review	All	M26	01/2026	First commercial version of AWARE module

**2022 KoM MoM to be delivered ?
Delta KoM MoM to be delivered ?**



In a nutshell

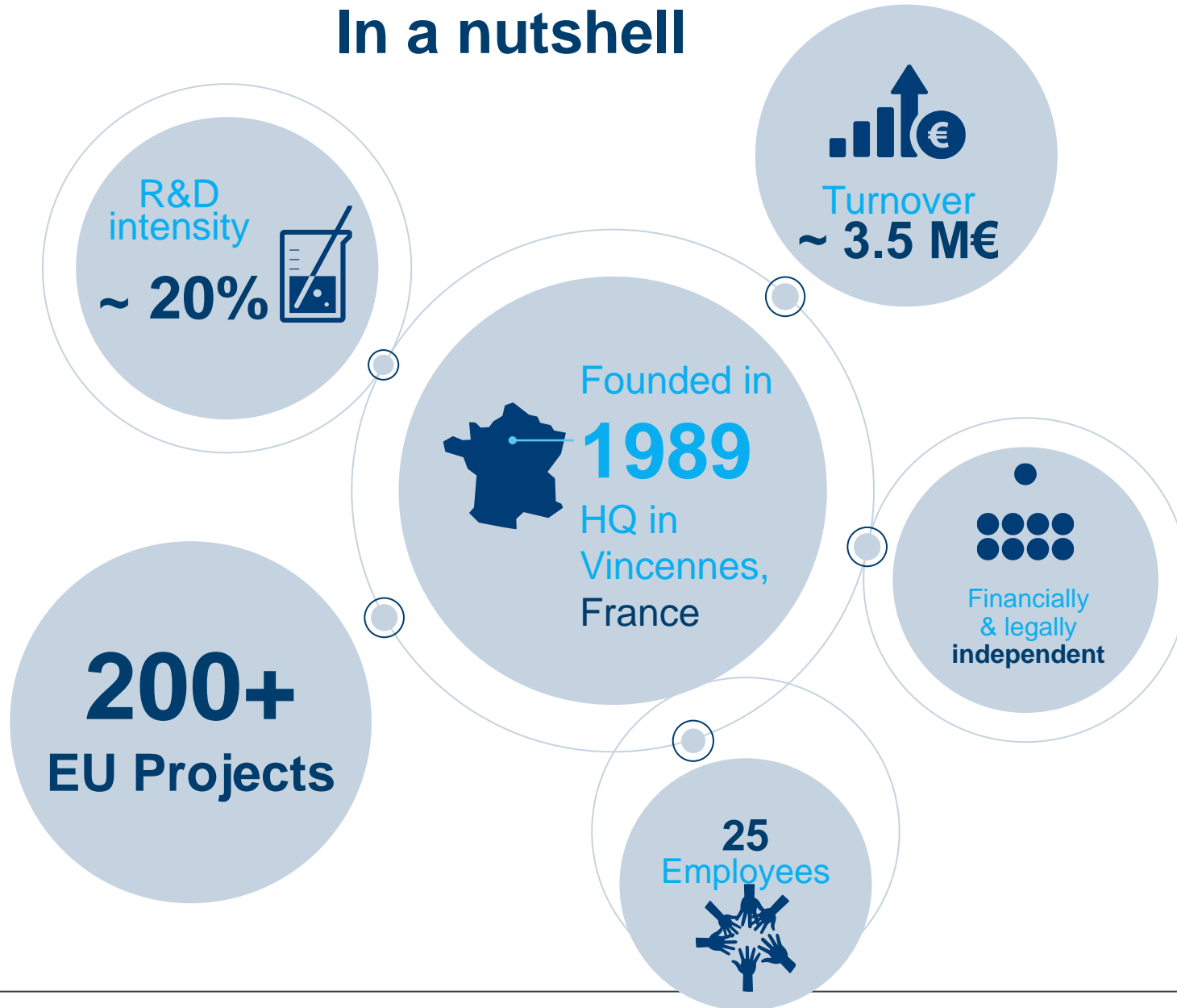

By Your Side to Take on Your Challenges



**Business
Consulting
& Management**

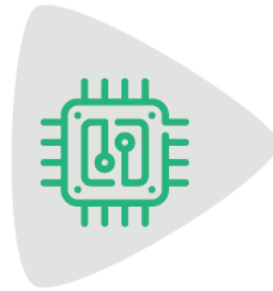

**Technology
Consulting**



**Research,
Development
& Innovation**

Our Services

Research, Development & Innovation

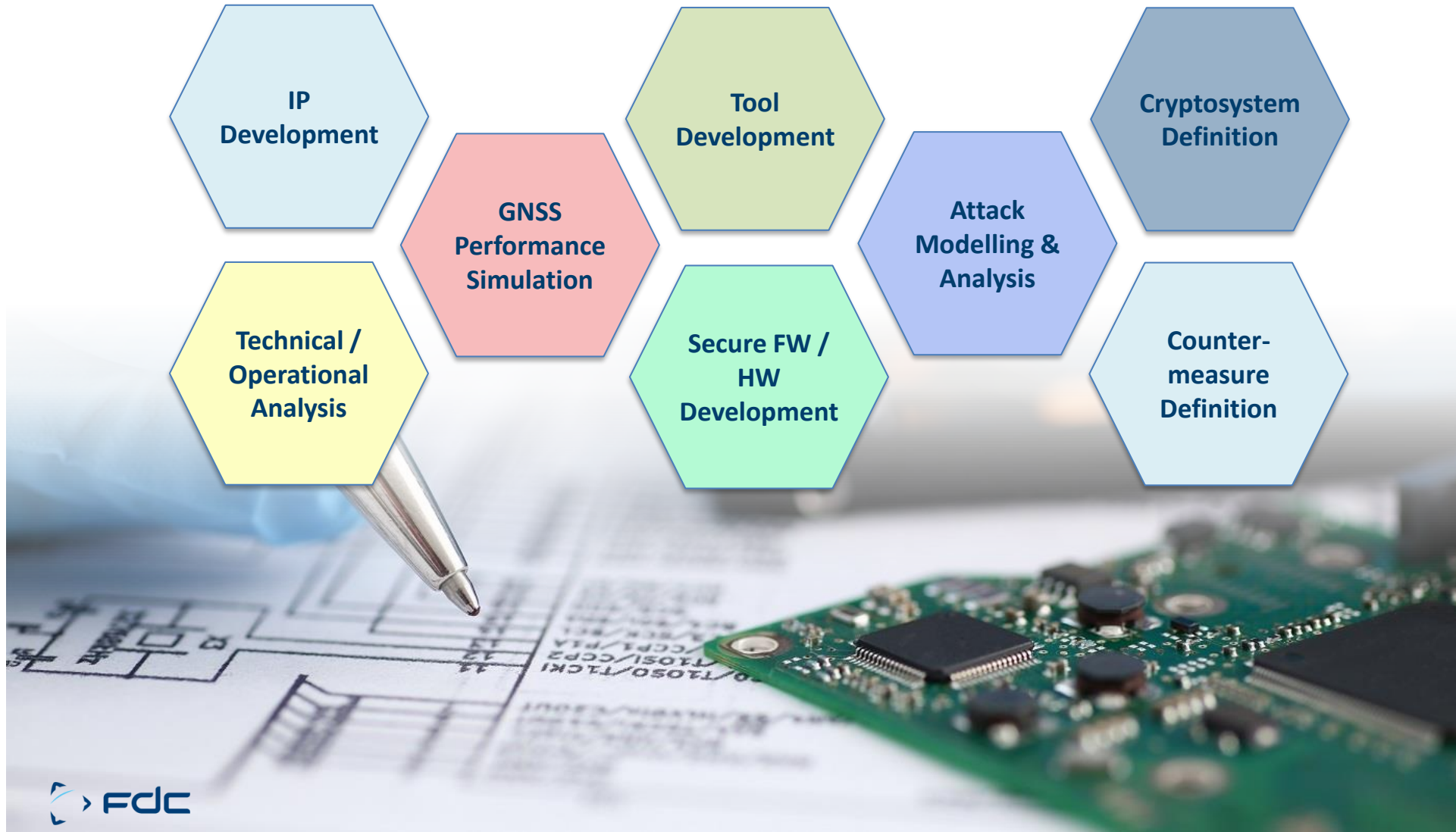

DRACONAV module

- Mono-frequency L1 Multi-GNSS engine
- GPS, Galileo, GLONASS, QZSS, COMPASS
- SBAS: EGNOS, WAAS, MSAS, GAGAN
- GNSS signal attacks detection and mitigation algorithms (Jamming/interference, Spoofing, Replay) – Up to 16 countermeasures
- PVT Level of Confidence (LOC) and type of attack indicators
- Estimate of true position under attack (dead reckoning support)
- Firmware and hardware integrity control
- Secure memory for sensitive data
- Secure firmware upgrade and module configuration
- ISO7816-4 protocol compliant with Smart Digital Tachograph regulation



EUSPA Fundamental Element PATROL Project

Purpose

Develop, supply and test Galileo's Open Service Navigation Message Authentication (OS NMA) to smart tachographs and other positioning applications.

Achievement

- TESEO 5 (L1/L5 E1/E5)
- Firmware developed by FDC using STM TESEO 5 SDK
- Secure firmware fully developed by FDC
- TRL 7 GNSS receiver prototype focusing on OSNMA and advanced GNSS attack detection & mitigation
- IT security: fully compliant with SmartDT regulation
- Full OSNMA v1.1 support

Supported by:



- PATROL Stage 1 (receiver) delivered to JRC in November 2018
- PATROL Stage 2 (module) starting soon

EUSPA Fundamental Element GEARS Project

Purpose

Galileo Authenticated Robust timing System.

- Objectives**
- Improving performances and resilience of Galileo and GNSS Timing receiver
 - Develop and demonstrate the effectiveness of unique Galileo services to operators
 - Strengthen market adoption through standardisation activities

Supported by:



European
Global Navigation
Satellite Systems
Agency



GEARS and PATROL implemented a prototype of TESEO5 module

- **Multi**-frequency Multi-GNSS engine
 - GPS, Galileo, GLONASS, QZSS, BEIDOU
 - SBAS: EGNOS, WAAS, MSAS, GAGAN
- **Extended** GNSS signal attacks detection and mitigation algorithms (Jamming/interference, Spoofing, Replay) – Up to **20** countermeasures
- **OSNMA for test phase**
- **HAS/ACAS Capable**
- PVT Level of Confidence (LOC) and type of attack indicators
- Estimate of true position under attack (dead reckoning support)
- **Extended** Firmware and hardware integrity control
- Secure memory for sensitive data
- Secure firmware upgrade and module configuration

The development is compliant with standard ISO21434



Tasks led by FDC



Tasks led by FDC

FDC will led in AWARE

- WP3: Products development
- WP4: AWARE integration and validation

FDC is now used to develop this kind of products.

FDC will also develop a lot of test tool such as Galileo signal generator supporting EWSS message

Update on Galileo EWSS





THANK YOU
FOR YOUR ATTENTION

telespazio.com

